

DH63LCB

Inductance Range: 1.2~150μH

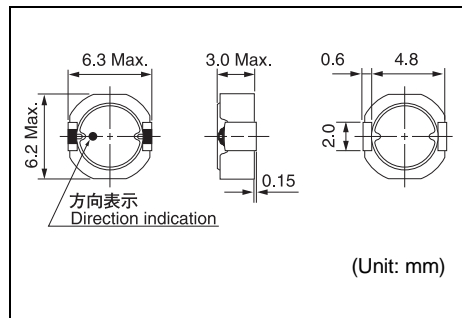

Recommended patterns 推奨パターン図

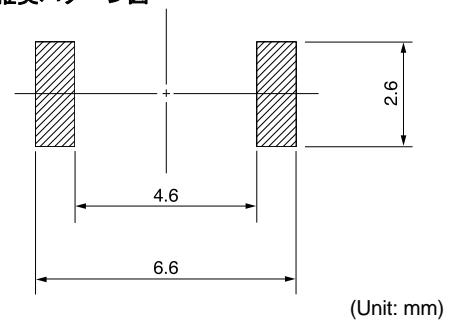

FEATURES 特長

- High reliability for vehicle application.
- Operating temperature range : -55°C~+125°C
- Low profile (6.2 × 6.3mm Max. square, 3.0mm Max. height).
- Magnetically shielded construction and low DC resistance.
- Suitable for large currents.
- Ideal for a variety of DC-DC converter inductor applications.
- RoHS compliant.
- 車載機器向け信頼性向上品
- 使用温度範囲 : -55°C~+125°C
- 小型薄形構造(6.2 × 6.3mm角Max. 高さ3.0mm Max.)
- 閉磁路構造、低直流抵抗
- 大電流対応
- 各種機器のDC-DCコンバータ用インダクタに最適
- RoHS指令対応

TOKO STANDARD PART NUMBERS 東光 標準品一覧

TYPE DH63LCB (With Ferrite Shield) 閉磁路タイプ(リングコア有り) (Quantity/reel; 1,500 PCS)

東光品番	インダクタンス ⁽¹⁾	許容差	直流抵抗 ⁽²⁾	直流重畳許容電流 ⁽³⁾	温度上昇許容電流 ⁽³⁾
TOKO Part Number	Inductance ⁽¹⁾ L (μH)	Tolerance (%)	DC Resistance ⁽²⁾ (mΩ) Max.	Inductance Decrease Current ⁽³⁾ (A) Max. $\frac{\Delta L}{L} = 30\%$	Temperature Rise Current ⁽³⁾ $\Delta T = 20^\circ\text{C}$ (A) Max.
A1006AYW-1R2M	1.2	± 20	20	2.40	3.20
A1006AYW-2R4M	2.4	± 20	24	1.90	2.70
A1006AYW-3R0M	3.0	± 20	28	1.60	2.40
A1006AYW-4R7M	4.7	± 20	37	1.30	2.00
A1006AYW-7R5M	7.5	± 20	51	1.00	1.70
A1006AYW-100M	10.0	± 20	71	0.88	1.30
A1006AYW-150M	15.0	± 20	105	0.69	1.10
A1006AYW-220M	22.0	± 20	145	0.57	0.90
A1006AYW-330M	33.0	± 20	220	0.47	0.70
A1006AYW-470M	47.0	± 20	340	0.39	0.57
A1006AYW-680M	68.0	± 20	460	0.32	0.46
A1006AYW-101M	100.0	± 20	640	0.27	0.38
A1006AYW-151M	150.0	± 20	1070	0.21	0.29

- (1) Inductance is measured with a LCR meter 4284A (Agilent Technologies) or equivalent.
Test frequency at 100kHz
- (2) DC Resistance is measured with a Digital Multimeter TR6871 (Advantest) or equivalent.
- (3) Maximum allowable DC current is that which inductance decrease current, or temperature rise current, whichever is smaller.
- Inductance decrease current : The inductance value decreases 30% by the excitation of DC current. (reference ambient temperature 125°C)
 - Temperature rise current : The temperature rises 20°C by excitation of DC current. (reference ambient temperature 20°C)

- (1) インダクタンスはLCRメータ4284A(Agilent Technologies)または同等品により測定する。
測定周波数は100kHz。
- (2) 直流抵抗はデジタルマルチメータTR6871(Advantest)または同等品により測定する。
- (3) 最大許容電流 : 直流重畳許容電流値と温度上昇許容電流値の何れか小さい値。
- 直流重畳許容電流 : 直流重畳特性においてインダクタンス値が30%低下した時の電流値。(周囲温度125°C)
 - 温度上昇許容電流 : 直流を流した時の巻線温度上昇が20°Cに達する電流値。(周囲温度20°C)