

## D73F / D75F

Inductance Range: 1.0~100μH (D73F), 1.0~470μH (D75F)

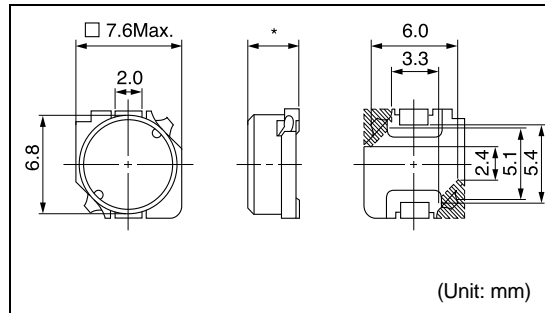

### Recommended patterns 推奨パターン図

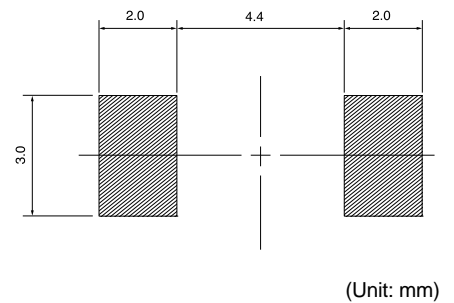

Note \*: D73F ; 3.5mm Max. height  
D75F ; 5.1mm Max. height

### FEATURES 特長

- Low-profile (7.6mm Max. square, 3.5 and 5.1mm Max. height).
- Open magnetic circuit construction.
- Suitable for large current.
- Ideal for a variety of DC-DC converter inductor applications.
- RoHS compliant.
- 低背 (7.6mm角Max.、高さ3.5および5.1mm Max.)
- 開磁路構造
- 大電流対応
- 各種機器のDC-DCコンバータ用インダクタに最適
- RoHS指令対応

### TOKO STANDARD PART NUMBERS 東光 標準品一覧

#### TYPE D73F Series (Unshielded) 開磁路タイプ(リングコア無し) (Quantity/reel; 1,000 PCS)

東光品番	インダクタンス <sup>(1)</sup>	許容差	直流抵抗 <sup>(2)</sup>	最大許容電流 <sup>(3)</sup>
TOKO Part Number	Inductance <sup>(1)</sup> (μH)	Tolerance (%)	DC Resistance <sup>(2)</sup> (Ω) Max.	Rated DC Current <sup>(3)</sup> (A) Max.
#636FY-1R0M	1.0	±20	0.018	3.00
#636FY-1R5M	1.5	±20	0.023	2.62
#636FY-2R2M	2.2	±20	0.029	2.27
#636FY-3R3M	3.3	±20	0.039	1.98
#636FY-4R7M	4.7	±20	0.050	1.75
#636FY-6R8M	6.8	±20	0.065	1.47
#636FY-100M	10.0	±20	0.086	1.28
#636FY-120M	12.0	±20	0.111	1.09
#636FY-150M	15.0	±20	0.143	0.98
#636FY-180M	18.0	±20	0.169	0.87
#636FY-220M	22.0	±20	0.202	0.80
#636FY-270M	27.0	±20	0.260	0.70
#636FY-330M	33.0	±20	0.312	0.63
#636FY-390M	39.0	±20	0.364	0.58
#636FY-470M	47.0	±20	0.442	0.53
#636FY-560M	56.0	±20	0.520	0.48
#636FY-680M	68.0	±20	0.650	0.42
#636FY-820M	82.0	±20	0.780	0.37
#636FY-101M	100.0	±20	1.027	0.33

continued from previous page 前頁より続く

### TYPE D75F Series (Unshielded) 開磁路タイプ(リングコア無し) (Quantity/reel; 1,000 PCS)

東光品番	インダクタンス <sup>(1)</sup>	許容差	直流抵抗 <sup>(2)</sup>	最大許容電流 <sup>(3)</sup>
TOKO Part Number	Inductance <sup>(1)</sup> (μH)	Tolerance (%)	DC Resistance <sup>(2)</sup> (Ω) Max.	Rated DC Current <sup>(3)</sup> (A) Max.
#646FY-1R0M	1.0	± 20	0.023	2.88
#646FY-1R5M	1.5	± 20	0.028	2.56
#646FY-2R2M	2.2	± 20	0.032	2.36
#646FY-3R3M	3.3	± 20	0.038	2.16
#646FY-4R7M	4.7	± 20	0.049	1.88
#646FY-6R8M	6.8	± 20	0.060	1.68
#646FY-100M	10.0	± 20	0.070	1.56
#646FY-120M	12.0	± 20	0.080	1.44
#646FY-150M	15.0	± 20	0.090	1.36
#646FY-180M	18.0	± 20	0.100	1.28
#646FY-220M	22.0	± 20	0.120	1.17
#646FY-270M	27.0	± 20	0.140	1.07
#646FY-330M	33.0	± 20	0.160	1.00
#646FY-390M	39.0	± 20	0.190	0.91
#646FY-470M	47.0	± 20	0.220	0.84
#646FY-560M	56.0	± 20	0.290	0.72
#646FY-680M	68.0	± 20	0.340	0.66
#646FY-820M	82.0	± 20	0.460	0.58
#646FY-101M	100.0	± 20	0.550	0.51
#646FY-121K	120.0	± 10	0.670	0.42
#646FY-151K	150.0	± 10	0.900	0.37
#646FY-181K	180.0	± 10	1.050	0.35
#646FY-221K	220.0	± 10	1.350	0.29
#646FY-271K	270.0	± 10	1.550	0.28
#646FY-331K	330.0	± 10	2.050	0.23
#646FY-391K	390.0	± 10	2.300	0.21
#646FY-471K	470.0	± 10	2.600	0.19

- (1) Inductance is measured with a LCR meter 4284A (Agilent Technologies) or equivalent.  
Test frequency at 100kHz.
- (2) DC resistance is measured with a Digital Multimeter TR6871 (Advantest) or equivalent.
- (3) Rated DC current is that which causes a 10% inductance reduction from the initial value, or coil temperature to rise by 40°C, whichever is smaller.  
(Reference ambient temperature 20°C)

- (1) インダクタンスはLCRメータ4284A (Agilent Technologies) または同等品により測定する。  
測定周波数は100kHz。
- (2) 直流抵抗はデジタルマルチメータTR6871 (Advantest) または同等品により測定する。
- (3) 最大許容電流は、直流重畳電流を流した時インダクタンスの値が初期値より10%減少する直流電流値、または直流電流により、コイルの温度が40°C上昇の何れか小さい値。  
(周囲温度20°Cを基準とする。)