

# APPLICATION MANUAL

Capacitor-less, Ultra Small Package, Low  $I_Q$   
200mA CMOS LDO Regulator IC  
TK681xxAMF/M5/S2

## CONTENTS

1 . DESCRIPTION	2
2 . FEATURES	2
3 . APPLICATIONS	2
4 . PIN CONFIGURATION	2
5 . BLOCK DIAGRAM	2
6 . ORDERING INFORMATION	3
7 . ABSOLUTE MAXIMUM RATINGS	3
8 . ELECTRICAL CHARACTERISTICS	4
9 . TEST CIRCUIT	7
10 . TYPICAL CHARACTERISTICS	9
11 . PIN DESCRIPTION	26
12 . APPLICATIONS INFORMATION	27
13 . PACKAGE OUTLINE	34
14 . NOTES	37
15 . OFFICES	37



# Capacitor-less, Ultra Small Package, Low I<sub>Q</sub> 200mA CMOS LDO Regulator TK681xxAMF/M5/S2

## 1. DESCRIPTION

The TK681xxAMF/M5/S2 is a CMOS LDO regulator. The package is the very small and thin HSON1214-4, the small and thin SON2017-6, and the small and versatile SOT23-5.

The IC is designed for portable applications with space requirements.

The IC can supply 200mA output current.

The IC offers low quiescent current.

The IC does not require a noise-bypass capacitor.

The output voltage is internally fixed from 1.2V to 4.2V.

## 2. FEATURES

- Capacitor-less  
(Without input capacitor, output capacitor, and noise-bypass capacitor)
- Package: HSON1214-4 / SON2017-6 / SOT23-5
- Low quiescent current
- Thermal and over current protection
- On/Off control
- High accuracy

## 3. APPLICATIONS

- Mobile communication
- Battery powered system
- Any electronic equipment

## 4. PIN CONFIGURATION

- HSON1214-4

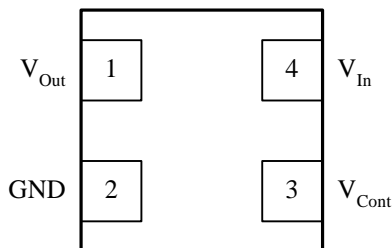

- SON2017-6

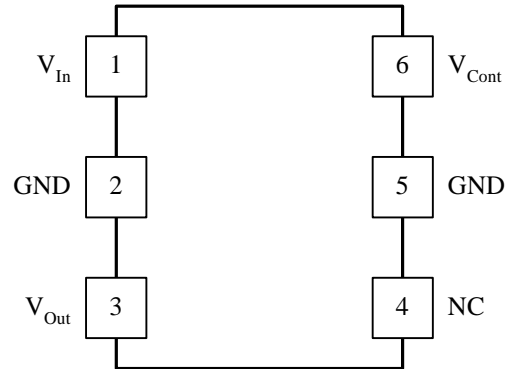

- SOT23-5

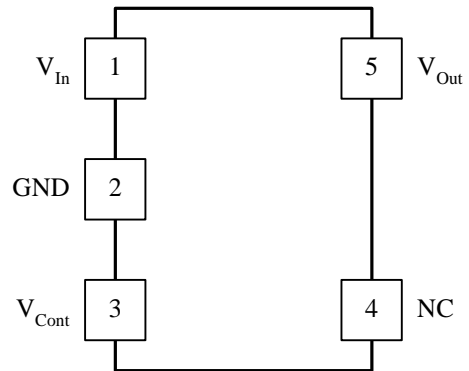

## 5. BLOCK DIAGRAM

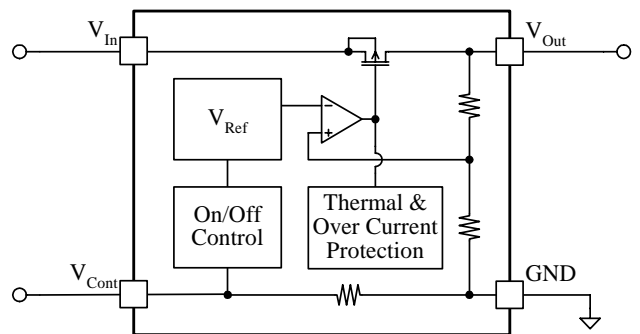

**6. ORDERING INFORMATION**

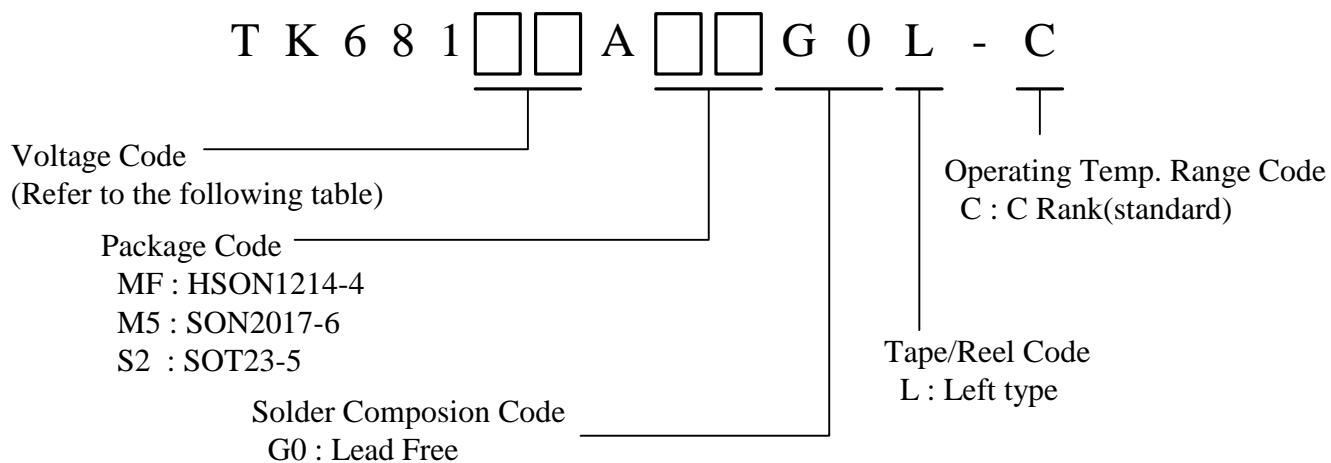

Output Voltage	Voltage Code	Output Voltage	Voltage Code	Output Voltage	Voltage Code
1.2V	12	2.7V	27	3.2V	32
1.3V	13	2.8V	28	3.3V	33
1.5V	15	2.85V	01	3.5V	35
1.8V	18	2.9V	29	4.0V	40
2.5V	25	3.0V	30		
2.6V	26	3.1V	31		

\*If you need a voltage other than the value listed in the above table, please contact TOKO.

**7. ABSOLUTE MAXIMUM RATINGS**

T<sub>a</sub>=25°C

Parameter	Symbol	Rating	Units	Conditions
<b>Absolute Maximum Ratings</b>				
Input Voltage	V <sub>In,MAX</sub>	-0.3 ~ 6.0	V	
Output pin Voltage	V <sub>Out,MAX</sub>	-0.3 ~ V <sub>In</sub> +0.3	V	
Control pin Voltage	V <sub>Cont,MAX</sub>	-0.3 ~ 6.0	V	
Storage Temperature Range	T <sub>stg</sub>	-55 ~ 150	°C	
Power Dissipation	P <sub>D</sub>	400 500	mW	Internal Limited T <sub>j</sub> =150°C *, When mounted on PCB HSON1214-4 SON2017-6 / SOT23-5
<b>Operating Condition</b>				
Operational Temperature Range	T <sub>OP</sub>	-40 ~ 85	°C	
Operational Voltage Range	V <sub>OP</sub>	1.7 ~ 6.0	V	

\* P<sub>D</sub> must be decreased at the rate of 3.2mW/°C(HSON1214-4), 4mW/°C(SON2017-6, SOT23-5) for operation above 25°C.

The maximum ratings are the absolute limitation values with the possibility of the IC breakage. When the operation exceeds this standard quality can not be guaranteed.

**8. ELECTRICAL CHARACTERISTICS**

The parameters with min. or max. values will be guaranteed at  $T_a=T_j=25^{\circ}\text{C}$  with test when manufacturing or SQC(Statistical Quality Control) methods. The operation between  $-40 \sim 85^{\circ}\text{C}$  is guaranteed when design.

$$V_{In}=V_{Out,TYP}+1V, V_{Cont}=1.2V, T_a=T_j=25^{\circ}\text{C}$$

Parameter	Symbol	Value			Units	Conditions
		MIN	TYP	MAX		
Output Voltage	$V_{Out}$	Refer to TABLE 1, 2			V	$I_{Out}=5\text{mA}$
Line Regulation	LinReg	-	0.0	4.0	mV	$\Delta V_{In}=1V$
Load Regulation	LoaReg	Refer to TABLE 1, 2			mV	Refer to TABLE 1, 2
Dropout Voltage *1	$V_{Drop}$	Refer to TABLE 1, 2			mV	Refer to TABLE 1, 2
Maximum Load Current *2	$I_{Out,MAX}$	210	350	-	mA	$V_{Out}=V_{Out,TYP}\times 0.9$
Quiescent Current	$I_Q$	-	12	24	$\mu\text{A}$	$I_{Out}=0\text{mA}, V_{Cont}=V_{In}$
Standby Current	$I_{Standby}$	-	0.01	0.1	$\mu\text{A}$	$V_{Cont}=0V$
GND Pin Current	$I_{GND}$	-	30	60	$\mu\text{A}$	$I_{Out}=50\text{mA}, V_{Cont}=V_{In}$
<b>Control Terminal</b>						
Control Current	$I_{Cont}$	-	0.7	1.4	$\mu\text{A}$	$V_{Cont}=1.2V$
Control Voltage	$V_{Cont}$	1.2	-	-	V	$V_{Out}$ On state
		-	-	0.2	V	$V_{Out}$ Off state

Reference Value						
Output Voltage / Temp.	$\Delta V_{Out}/\Delta T_a$	-	100	-	ppm/ $^{\circ}\text{C}$	$I_{Out}=5\text{mA}$
Output Noise Voltage (TK68128A)	$V_{Noise}$	-	45	-	$\mu\text{V}_{rms}$	$C_{Out}=1.0\mu\text{F}, I_{Out}=30\text{mA}, \text{BPF}=400\text{Hz}\sim 80\text{kHz}$
Ripple Rejection (TK68128A)	RR	-	52	-	dB	$C_{Out}=1.0\mu\text{F}, I_{Out}=10\text{mA}, f=1\text{kHz}$
Rise Time (TK68128A)	$t_r$	-	85	-	$\mu\text{s}$	$C_{Out}=1.0\mu\text{F}, V_{Cont} : \text{Pulse Wave (100Hz)}, V_{Cont} \text{ On} \rightarrow V_{Out}\times 95\% \text{ point}$

\*1: For  $V_{Out} \leq 1.7V$ , no regulations.

\*2: The maximum output current is limited by power dissipation.

The maximum load current is the current where the output voltage decreases to 90% by increasing the output current at  $T_j=25^{\circ}\text{C}$ , compared to the output voltage specified at  $V_{In}=V_{Out,TYP}+1V$ . The maximum load current indicates the current at which over current protection turn on.

For all output voltage products, the maximum output current for normal operation without operating any protection is 200mA. Accordingly, LoaReg and  $V_{Drop}$  are specified on the condition that  $I_{Out}$  is less than 200mA.

General Note

Parameters with only typical values are just reference. (Not guaranteed)

The noise level is dependent on the output voltage, the capacitance and capacitor characteristics.

**TABLE 1.** Preferred Product (TK681xxAMF)

Part Number	Output Voltage			Load Regulation				Dropout Voltage			
				I <sub>Out</sub> =5 ~ 100mA		I <sub>Out</sub> =5 ~ 200mA		I <sub>Out</sub> =100mA		I <sub>Out</sub> =200mA	
	MIN	TYP	MAX	TYP	MAX	TYP	MAX	TYP	MAX	TYP	MAX
	V	V	V	mV	mV	mV	mV	mV	mV	mV	mV
TK68112AMF	1.175	1.200	1.225	11	44	21	84	-	-	-	-
TK68113AMF	1.275	1.300	1.325	11	44	21	84	-	-	-	-
TK68115AMF	1.475	1.500	1.525	11	44	22	88	-	-	-	-
TK68118AMF	1.775	1.800	1.825	12	48	22	88	130	205	265	445
TK68125AMF	2.475	2.500	2.525	12	48	24	96	95	145	185	310
TK68126AMF	2.574	2.600	2.626	13	52	24	96	90	145	180	300
TK68127AMF	2.673	2.700	2.727	13	52	24	96	90	140	175	295
TK68128AMF	2.772	2.800	2.828	13	52	24	96	85	135	170	290
TK68101AMF	2.821	2.850	2.879	13	52	24	96	85	135	170	285
TK68129AMF	2.871	2.900	2.929	13	52	25	100	85	135	165	285
TK68130AMF	2.970	3.000	3.030	13	52	25	100	85	130	165	280
TK68131AMF	3.069	3.100	3.131	13	52	25	100	80	130	160	275
TK68132AMF	3.168	3.200	3.232	13	52	25	100	80	125	160	270
TK68133AMF	3.267	3.300	3.333	13	52	25	100	80	125	155	265
TK68135AMF	3.465	3.500	3.535	14	56	26	104	75	120	150	255
TK68140AMF	3.960	4.000	4.040	14	56	27	108	70	115	140	240

**TABLE 2.** Preferred Product (TK681xxAM5/S2)

Part Number	Output Voltage			Load Regulation				Dropout Voltage			
				I <sub>Out</sub> =5 ~ 100mA		I <sub>Out</sub> =5 ~ 200mA		I <sub>Out</sub> =100mA		I <sub>Out</sub> =200mA	
	MIN	TYP	MAX	TYP	MAX	TYP	MAX	TYP	MAX	TYP	MAX
	V	V	V	mV	mV	mV	mV	mV	mV	mV	mV
TK68112AM5/S2	1.175	1.200	1.225	8	32	15	60	-	-	-	-
TK68113AM5/S2	1.275	1.300	1.325	8	32	15	60	-	-	-	-
TK68115AM5/S2	1.475	1.500	1.525	8	32	16	64	-	-	-	-
TK68118AM5/S2	1.775	1.800	1.825	9	36	16	64	125	195	250	425
TK68125AM5/S2	2.475	2.500	2.525	9	36	18	72	85	135	170	290
TK68126AM5/S2	2.574	2.600	2.626	10	40	18	72	85	135	165	280
TK68127AM5/S2	2.673	2.700	2.727	10	40	18	72	85	130	165	275
TK68128AM5/S2	2.772	2.800	2.828	10	40	18	72	80	130	160	270
TK68101AM5/S2	2.821	2.850	2.879	10	40	18	72	80	125	155	265
TK68129AM5/S2	2.871	2.900	2.929	10	40	19	76	80	125	155	265
TK68130AM5/S2	2.970	3.000	3.030	10	40	19	76	75	120	150	255
TK68131AM5/S2	3.069	3.100	3.131	10	40	19	76	75	120	150	250
TK68132AM5/S2	3.168	3.200	3.232	10	40	19	76	75	120	145	250
TK68133AM5/S2	3.267	3.300	3.333	10	40	19	76	75	115	145	245
TK68135AM5/S2	3.465	3.500	3.535	11	44	20	80	70	110	140	235
TK68140AM5/S2	3.960	4.000	4.040	11	44	21	84	65	105	130	220

Notice.

Please contact your authorized TOKO representative for voltage availability.

**9. TEST CIRCUIT**

■ Test circuit for electrical characteristic

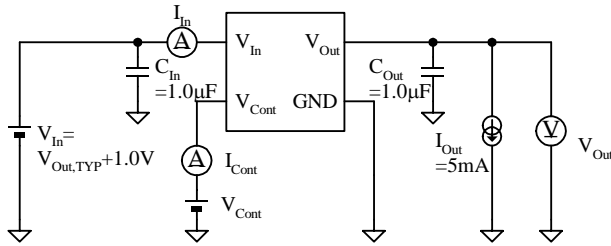

**Notice.**

The limit value of electrical characteristics is applied when  $C_{In}=1.0\mu\text{F}$ (Ceramic),  $C_{Out}=1.0\mu\text{F}$ (Ceramic). But  $C_{In}$ , and  $C_{Out}$  can be used with both ceramic and tantalum capacitors. Also, the IC provides stable operation even if without using capacitor.

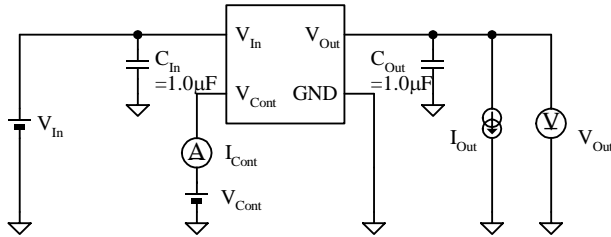

- $\Delta V_{Out}$  vs  $V_{In}$
- $V_{Drop}$  vs  $I_{Out}$
- $V_{Out}$  vs  $I_{Out}$
- $\Delta V_{Out}$  vs  $I_{Out}$
- $\Delta V_{Out}$  vs  $T_a$
- $V_{Drop}$  vs  $T_a$
- $I_{Out,MAX}$  vs  $T_a$
- $I_{Cont}$  vs  $V_{Cont}$ ,  $V_{Out}$  vs  $V_{Cont}$
- $I_{Cont}$  vs  $T_a$
- $V_{Cont}$  vs  $T_a$
- $V_{Noise}$  vs  $V_{In}$
- $V_{Noise}$  vs  $I_{Out}$
- $V_{Noise}$  vs  $V_{Out}$
- $V_{Noise}$  vs Frequency

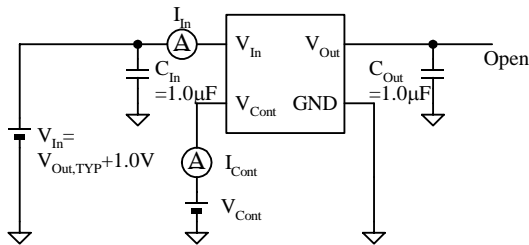

- $I_Q$  vs  $V_{In}$
- $I_{Standby}$  vs  $V_{In}$
- $I_Q$  vs  $T_a$

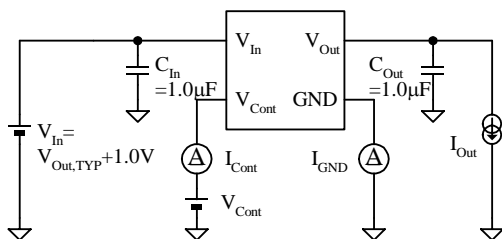

- $I_{GND}$  vs  $I_{Out}$
- $I_{GND}$  vs  $T_a$

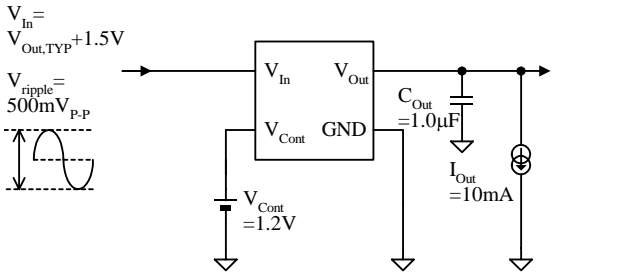

- RR vs  $V_{In}$
- RR vs Frequency
- RR vs Frequency

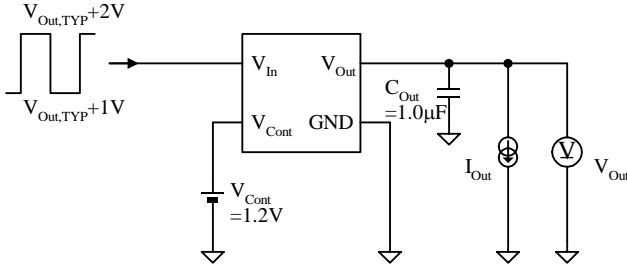

- Line Transient

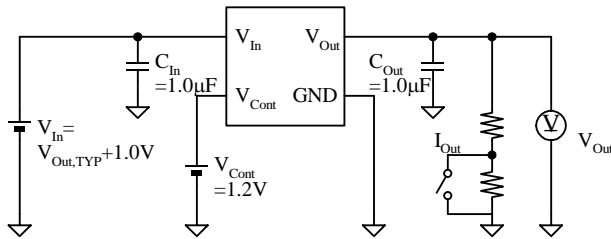

- Load Transient

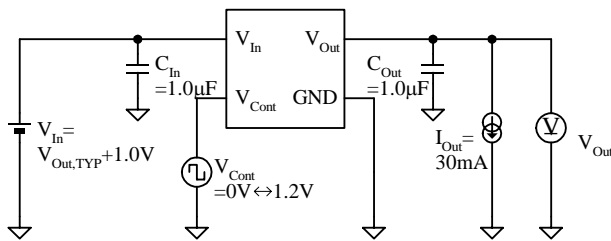

- On/Off Transient

**10. TYPICAL CHARACTERISTICS**

**10-1. DC CHARACTERISTICS**

■  $\Delta V_{Out}$  vs  $V_{In}$  (TK68112AMF/M5/S2)

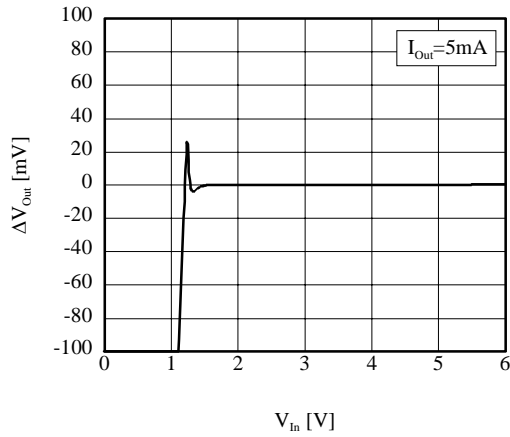

■  $\Delta V_{Out}$  vs  $V_{In}$  (TK68112AMF)

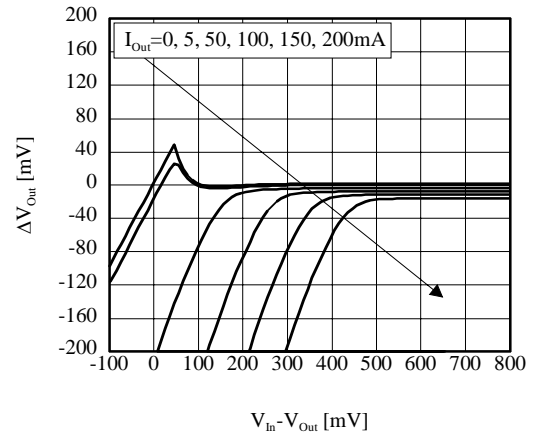

■  $\Delta V_{Out}$  vs  $V_{In}$  (TK68128AMF/M5/S2)

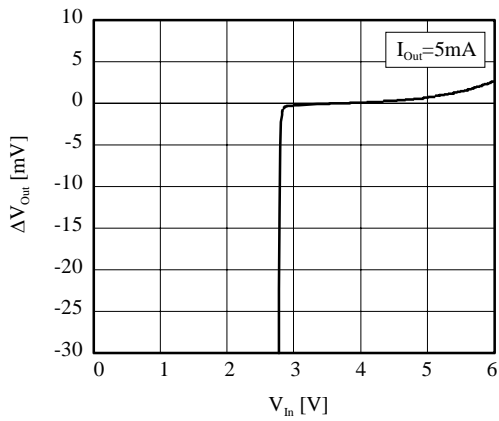

■  $\Delta V_{Out}$  vs  $V_{In}$  (TK68128AMF)

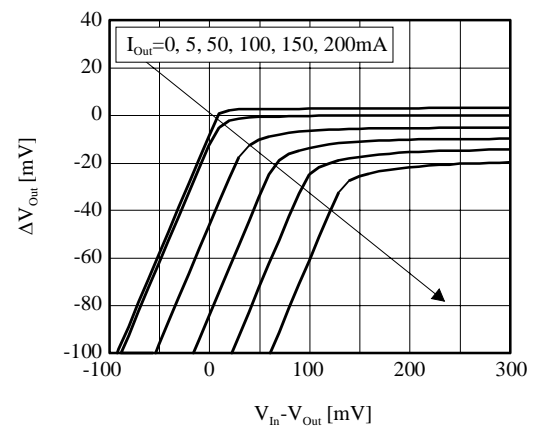

■  $\Delta V_{Out}$  vs  $V_{In}$  (TK68142AMF/M5/S2)

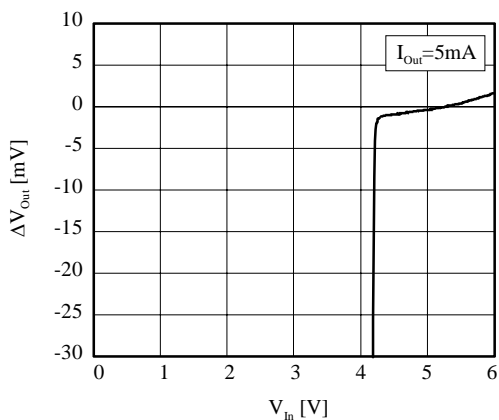

■  $\Delta V_{Out}$  vs  $V_{In}$  (TK68142AMF)

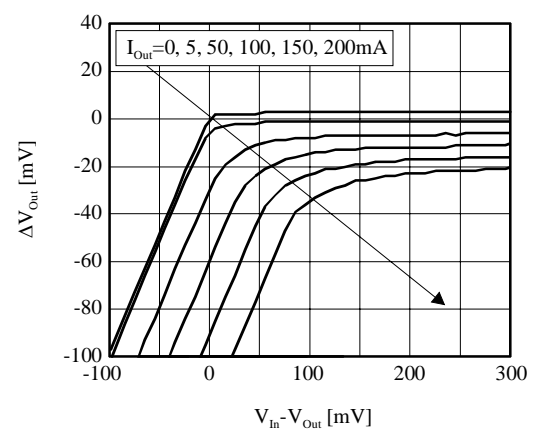

■  $\Delta V_{Out}$  vs  $I_{Out}$  (TK68112AM5/S2)

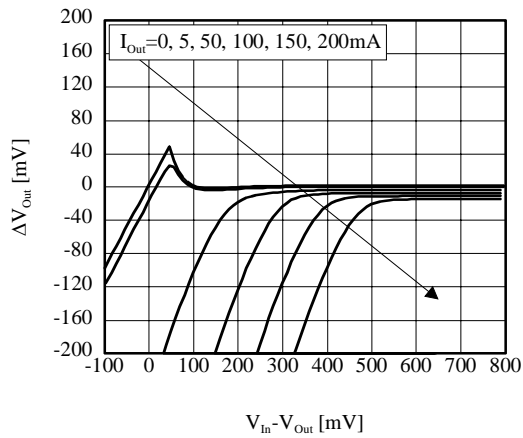

■  $\Delta V_{Out}$  vs  $I_{Out}$  (TK68128AM5/S2)

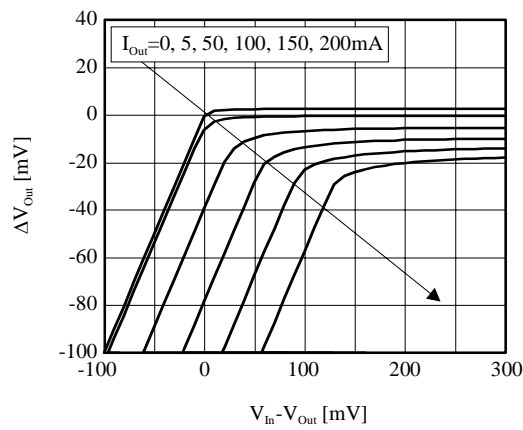

■  $V_{Drop}$  vs  $I_{Out}$  (TK68128AMF)

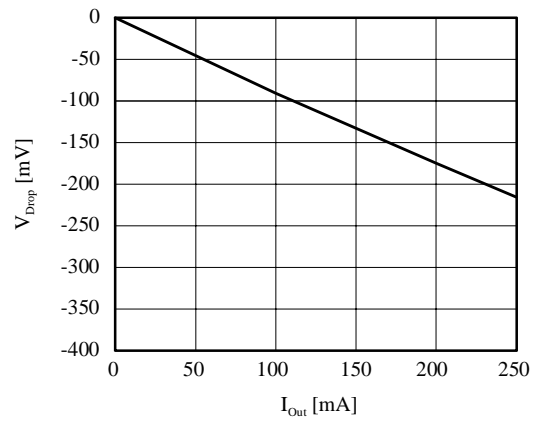

■  $\Delta V_{Out}$  vs  $I_{Out}$  (TK68142AM5/S2)

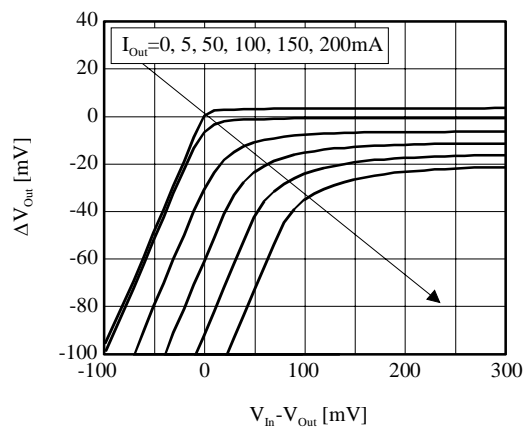

■  $V_{Drop}$  vs  $I_{Out}$  (TK68142AMF)

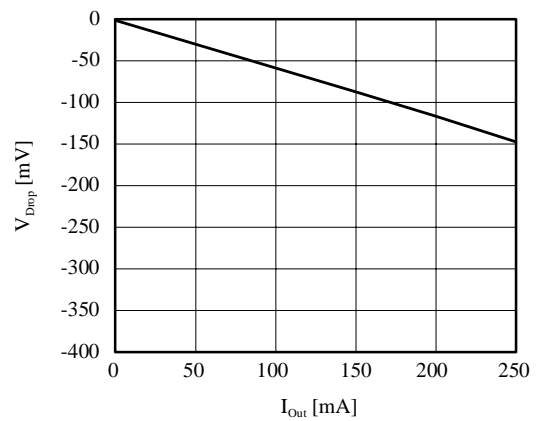

■  $V_{Out}$  vs  $I_{Out}$  (TK68112AMF/M5/S2)

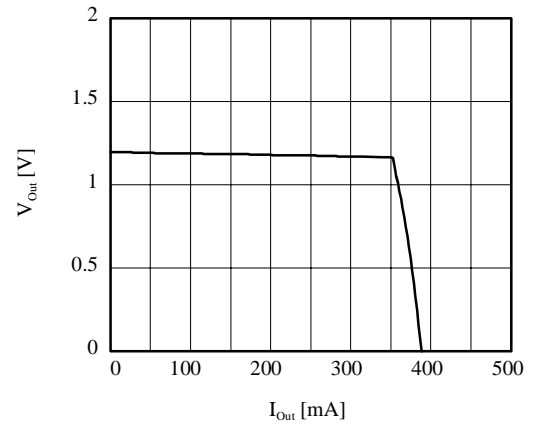

■  $V_{Drop}$  vs  $I_{Out}$  (TK68128AM5/S2)

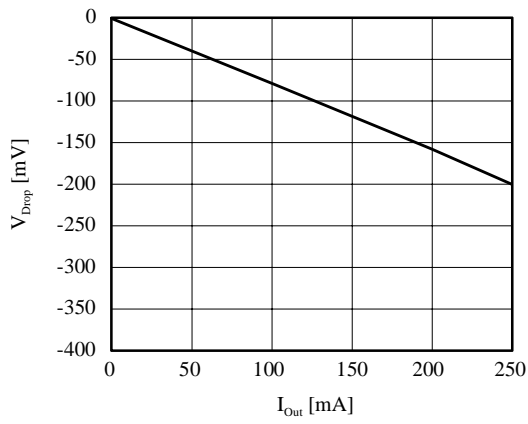

■  $V_{Out}$  vs  $I_{Out}$  (TK68128AMF/M5/S2)

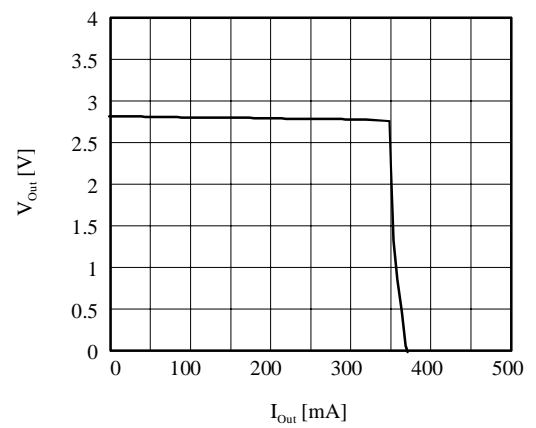

■  $V_{Drop}$  vs  $I_{Out}$  (TK68142AM5/S2)

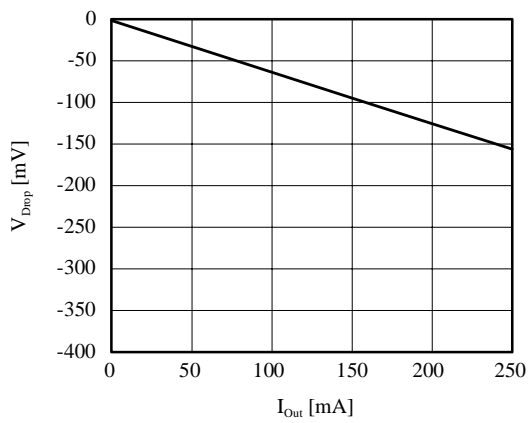

■  $V_{Out}$  vs  $I_{Out}$  (TK68142AMF/M5/S2)

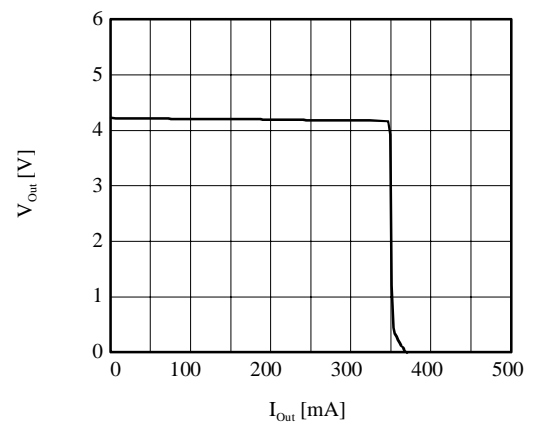

■  $\Delta V_{Out}$  vs  $I_{Out}$  (TK68112AMF)

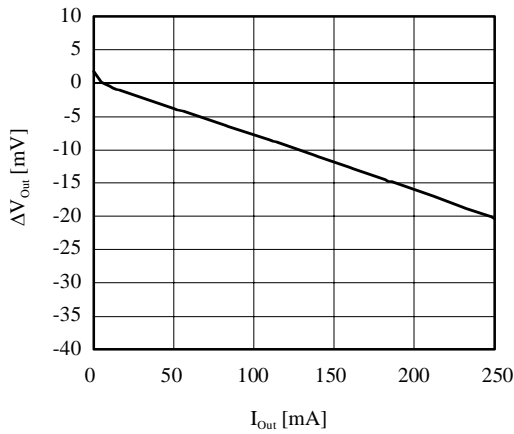

■  $\Delta V_{Out}$  vs  $I_{Out}$  (TK68112AM5/S2)

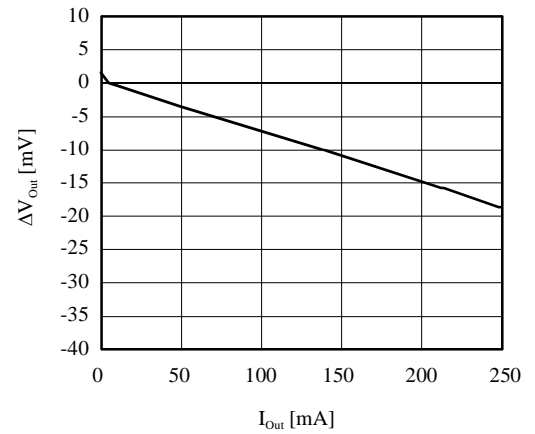

■  $\Delta V_{Out}$  vs  $I_{Out}$  (TK68128AMF)

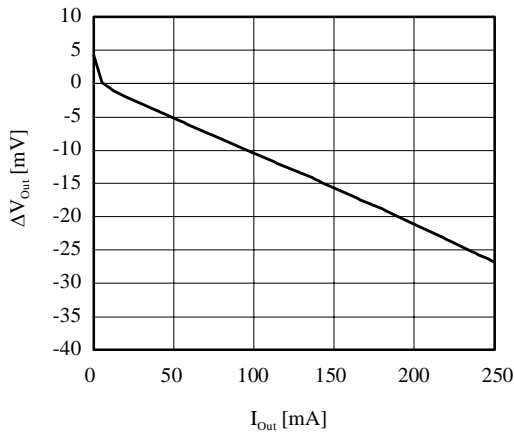

■  $\Delta V_{Out}$  vs  $I_{Out}$  (TK68128AM5/S2)

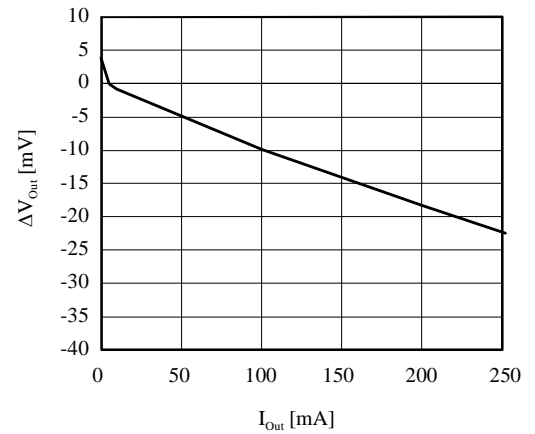

■  $\Delta V_{Out}$  vs  $I_{Out}$  (TK68142AMF)

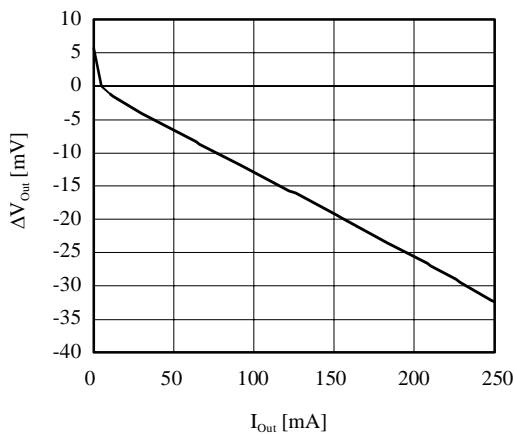

■  $\Delta V_{Out}$  vs  $I_{Out}$  (TK68142AM5/S2)

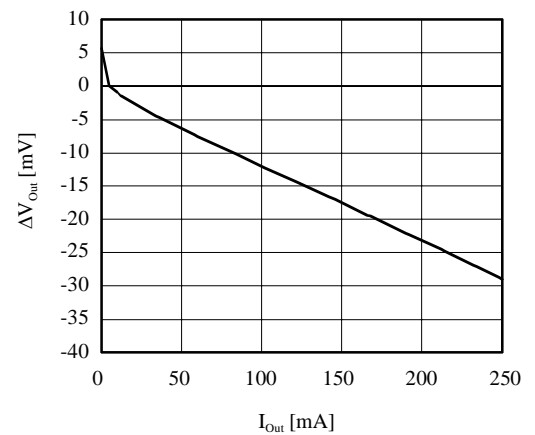

■  $\Delta V_{Out}$  vs  $T_a$  (TK68112AMF/M5/S2)

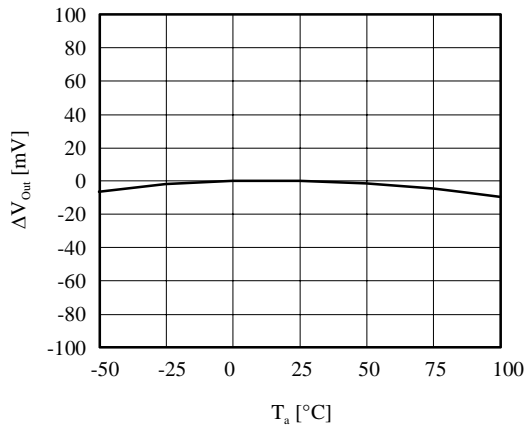

■  $\Delta V_{Out}$  vs  $T_a$  (TK68128AMF/M5/S2)

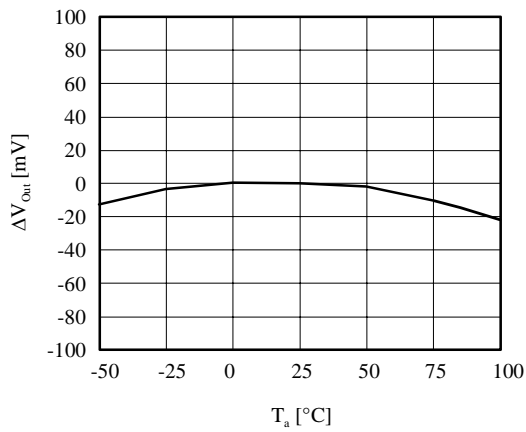

■  $V_{Drop}$  vs  $T_a$  (TK68128AMF)

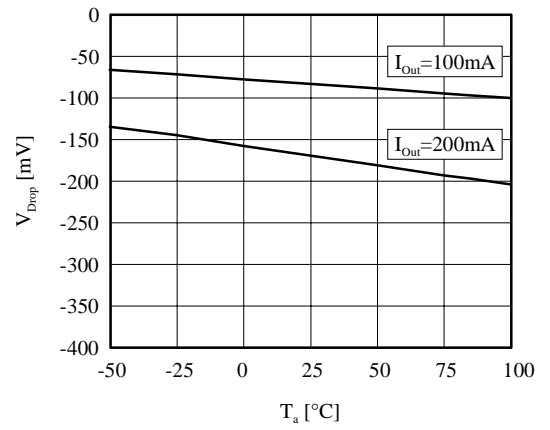

■  $\Delta V_{Out}$  vs  $T_a$  (TK68142AMF/M5/S2)

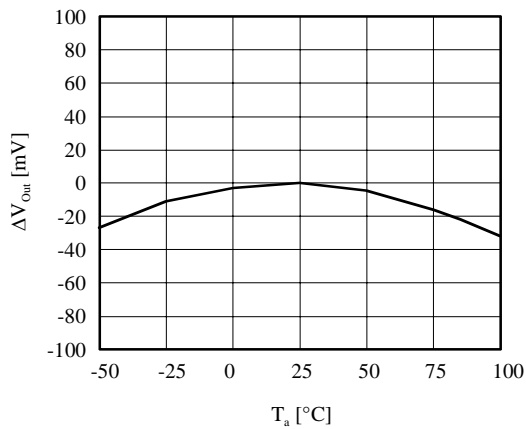

■  $V_{Drop}$  vs  $T_a$  (TK68142AMF)

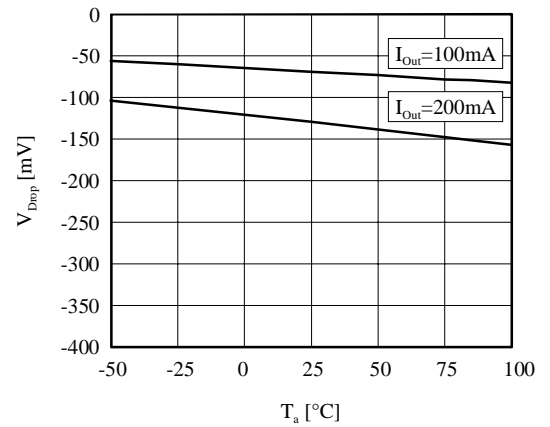

■  $I_{Out,MAX}$  vs  $T_a$  (TK68112AMF/M5/S2)

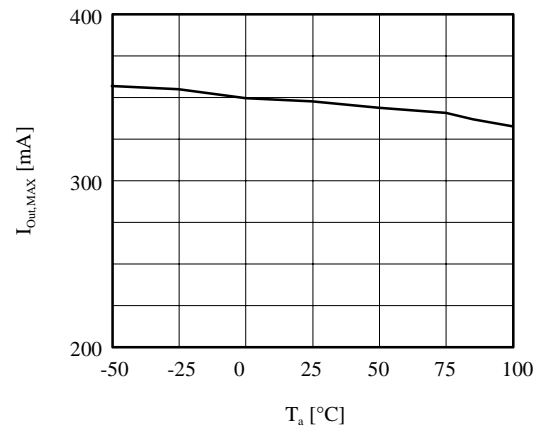

■  $V_{Drop}$  vs  $T_a$  (TK68128AM5/S2)

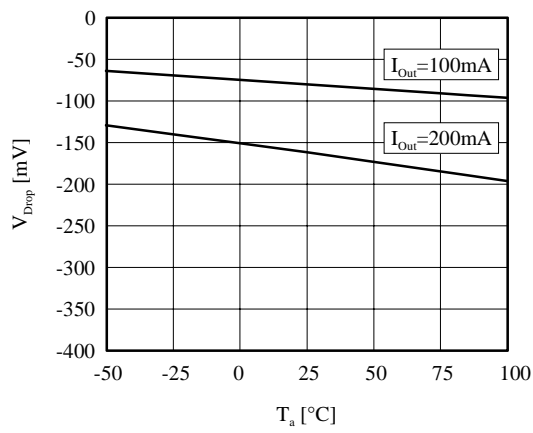

■  $I_{Out,MAX}$  vs  $T_a$  (TK68128AMF/M5/S2)

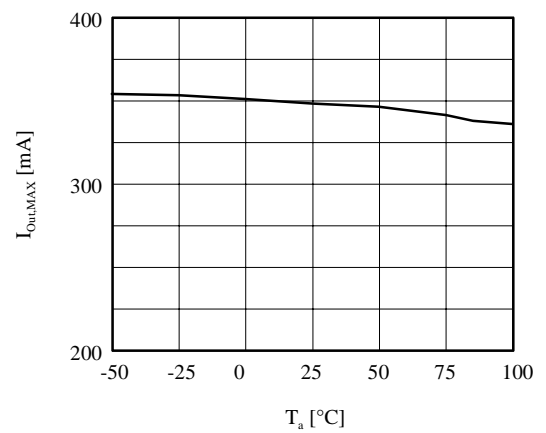

■  $V_{Drop}$  vs  $T_a$  (TK68142AM5/S2)

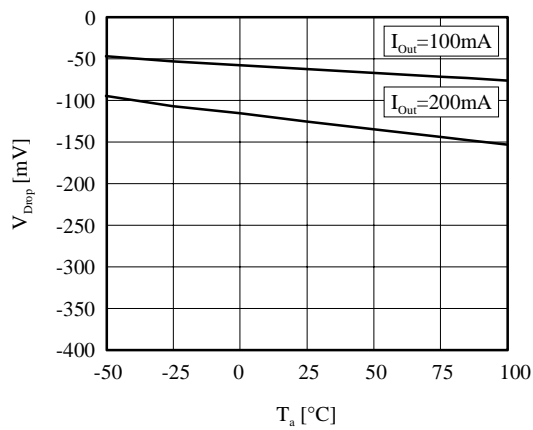

■  $I_{Out,MAX}$  vs  $T_a$  (TK68142AMF/M5/S2)

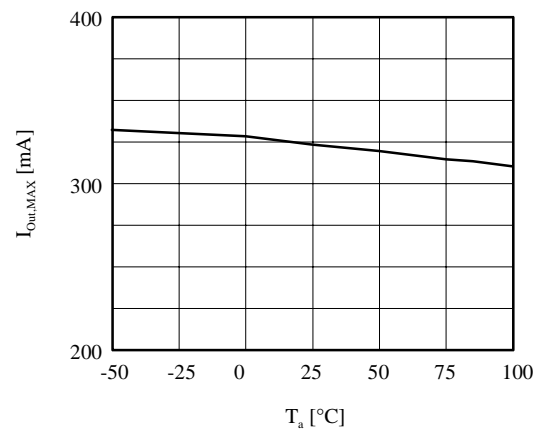

■  $I_Q$  vs  $V_{In}$  (TK68112AMF/M5/S2)

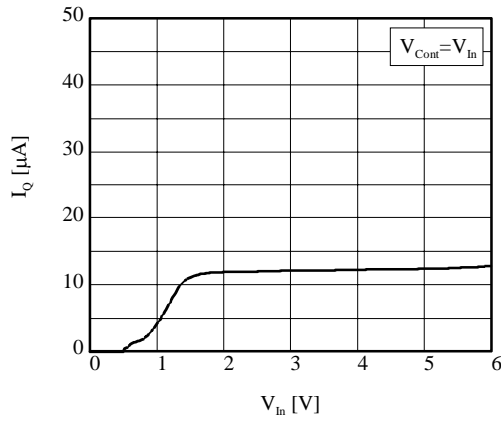

■  $I_{Standby}$  vs  $V_{In}$  (TK68112AMF/M5/S2)

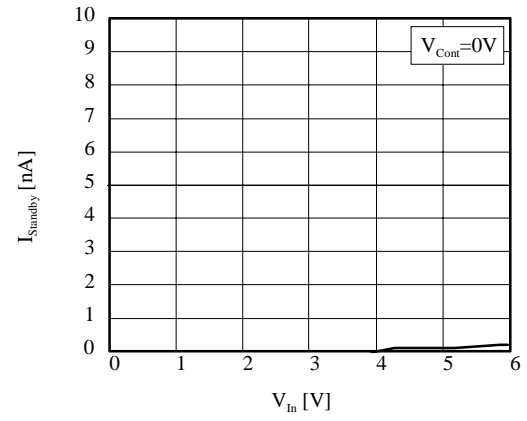

■  $I_Q$  vs  $V_{In}$  (TK68128AMF/M5/S2)

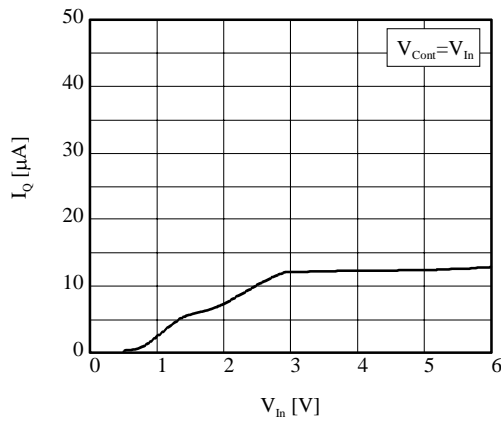

■  $I_{Standby}$  vs  $V_{In}$  (TK68128AMF/M5/S2)

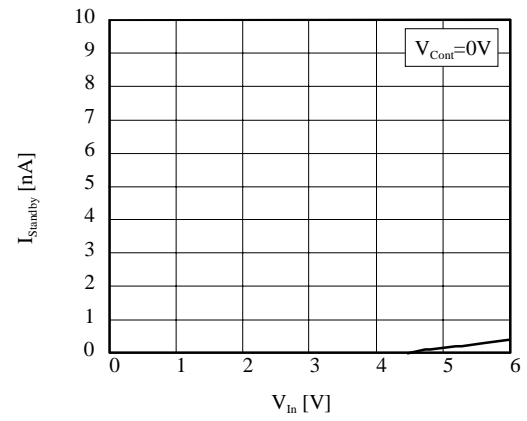

■  $I_Q$  vs  $V_{In}$  (TK68142AMF/M5/S2)

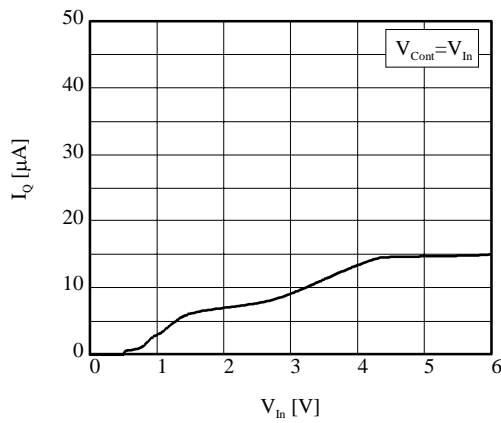

■  $I_{Standby}$  vs  $V_{In}$  (TK68142AMF/M5/S2)

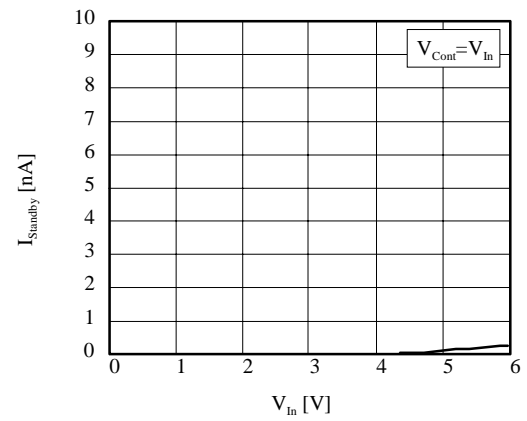

■  $I_{GND}$  vs  $I_{Out}$  (TK68112AMF/M5/S2)

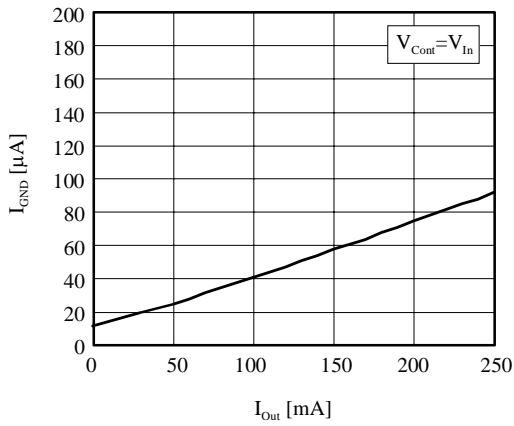

■  $I_Q$  vs  $T_a$  (TK68112AMF/M5/S2)

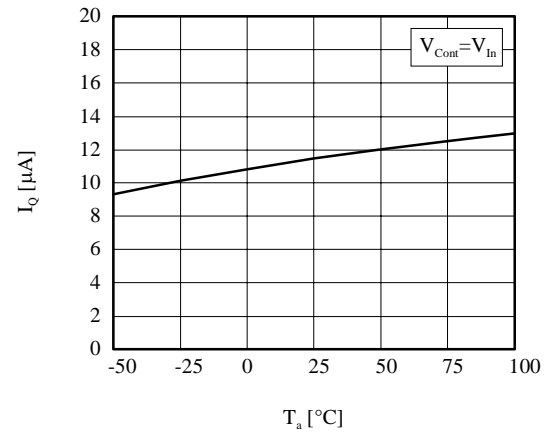

■  $I_{GND}$  vs  $I_{Out}$  (TK68128AMF/M5/S2)

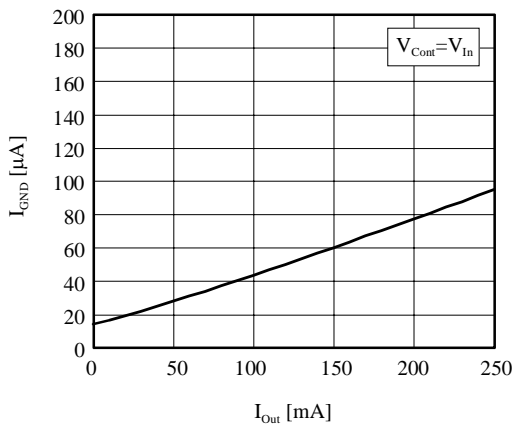

■  $I_Q$  vs  $T_a$  (TK68128AMF/M5/S2)

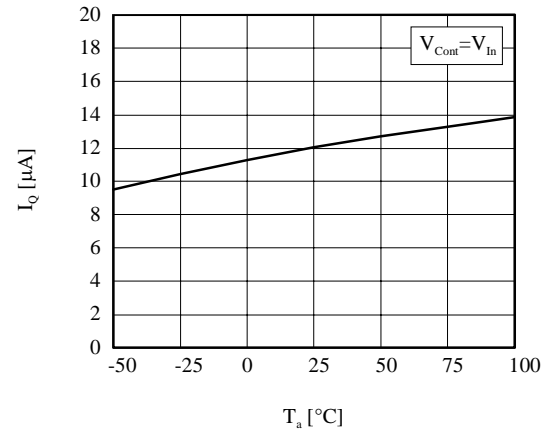

■  $I_{GND}$  vs  $I_{Out}$  (TK68142AMF/M5/S2)

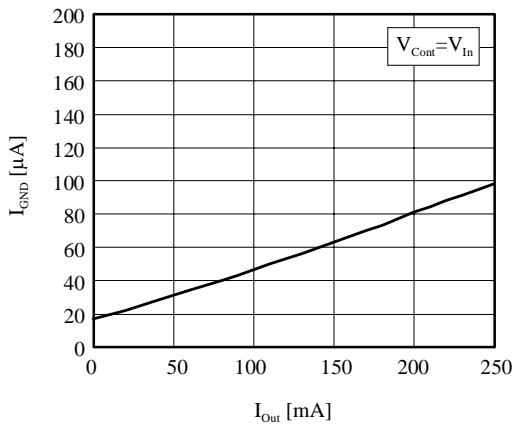

■  $I_Q$  vs  $T_a$  (TK68142AMF/M5/S2)

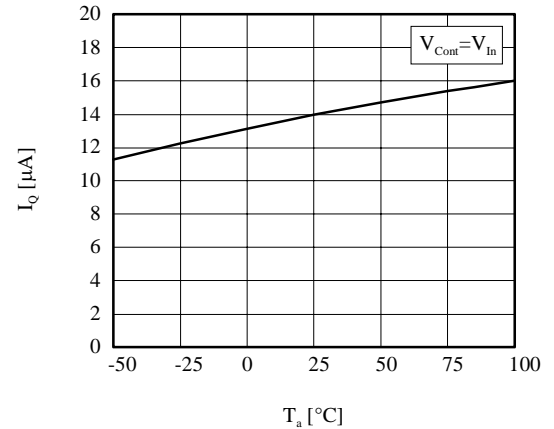

■  $I_{GND}$  vs  $T_a$  (TK68112AMF/M5/S2)

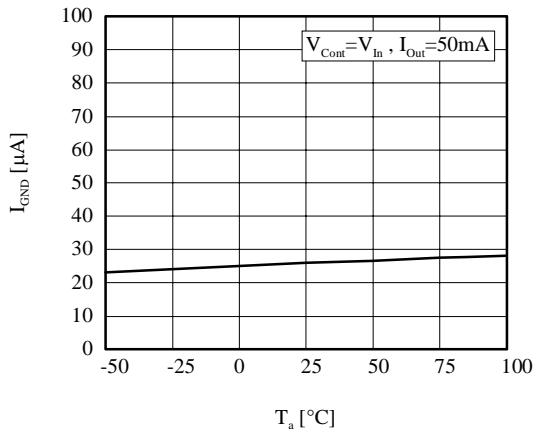

■  $I_{Cont}$  vs  $V_{Cont}$ ,  $V_{Out}$  vs  $V_{Cont}$  (TK68112AMF/M5/S2)

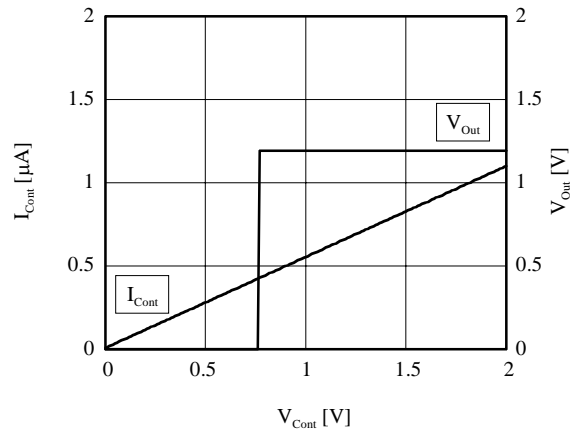

■  $I_{GND}$  vs  $T_a$  (TK68128AMF/M5/S2)

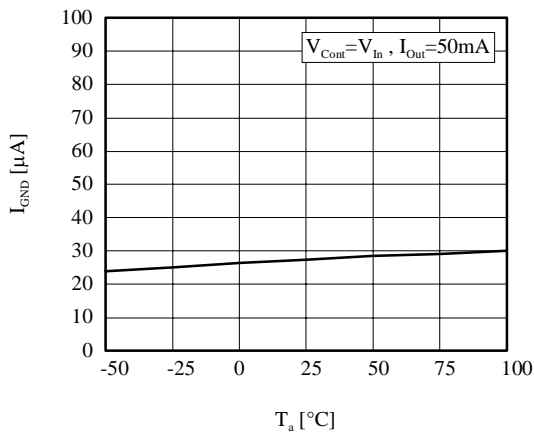

■  $I_{Cont}$  vs  $V_{Cont}$ ,  $V_{Out}$  vs  $V_{Cont}$  (TK68128AMF/M5/S2)

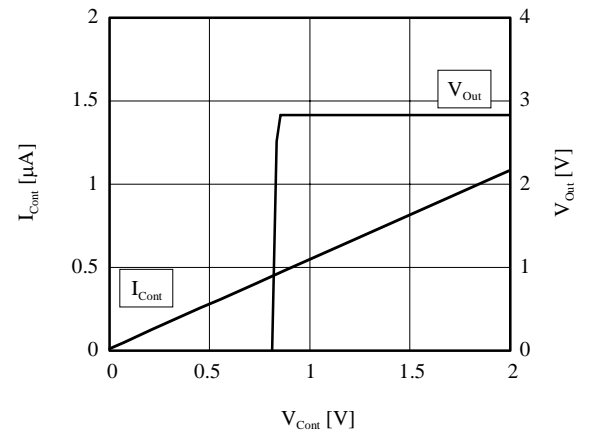

■  $I_{GND}$  vs  $T_a$  (TK68142AMF/M5/S2)

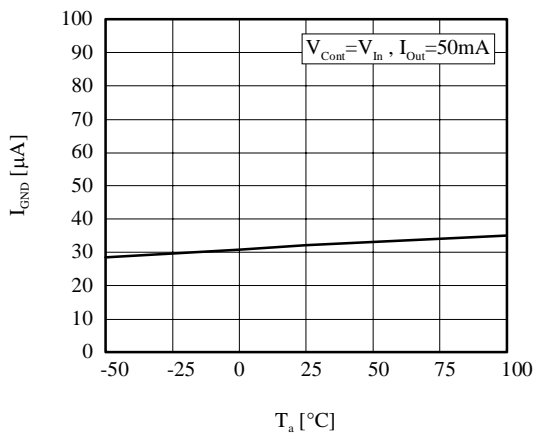

■  $I_{Cont}$  vs  $V_{Cont}$ ,  $V_{Out}$  vs  $V_{Cont}$  (TK68142AMF/M5/S2)

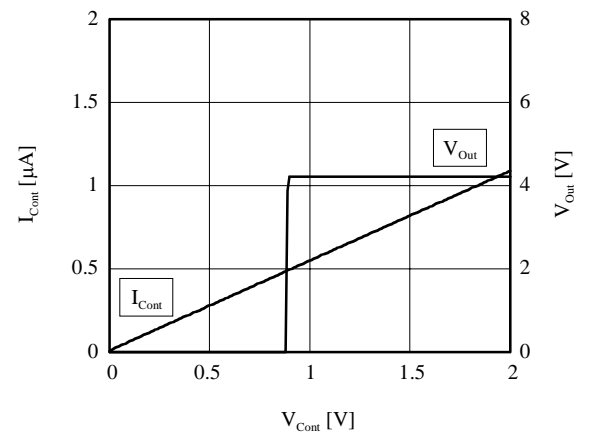

■  $V_{Cont}$  vs  $T_a$  (TK68112AMF/M5/S2)

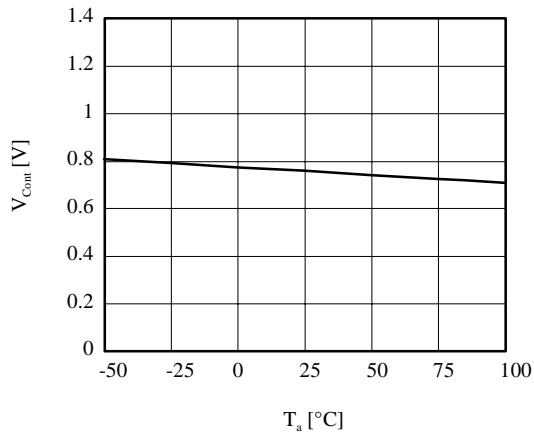

■  $I_{Cont}$  vs  $T_a$  (TK681xxAMF/M5/S2)

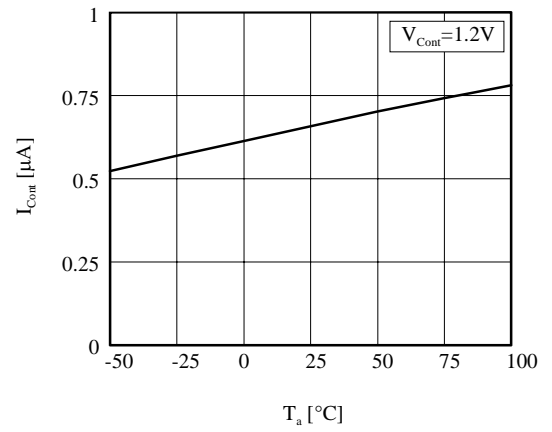

■  $V_{Cont}$  vs  $T_a$  (TK68128AMF/M5/S2)

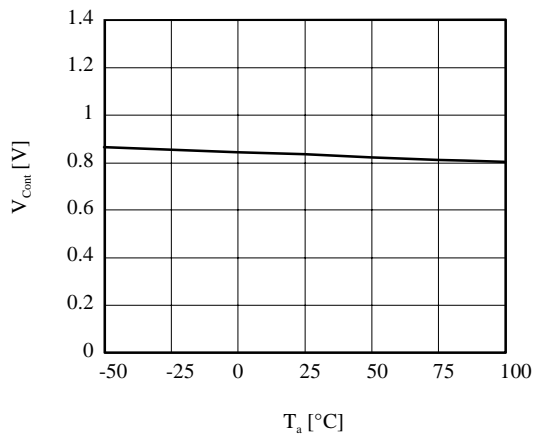

■  $V_{Cont}$  vs  $T_a$  (TK68142AMF/M5/S2)

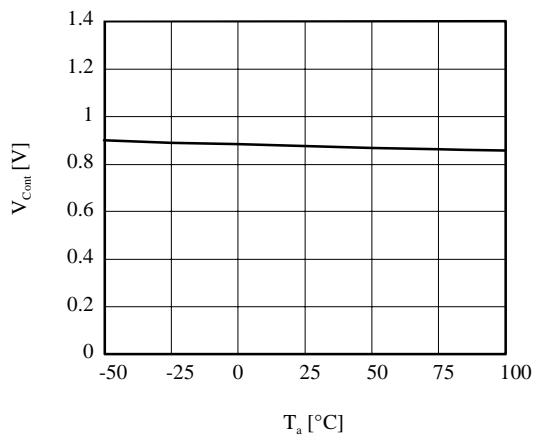

**10-2. AC CHARACTERISTICS**

■ RR vs  $V_{In}$  (TK68112AMF/M5/S2)

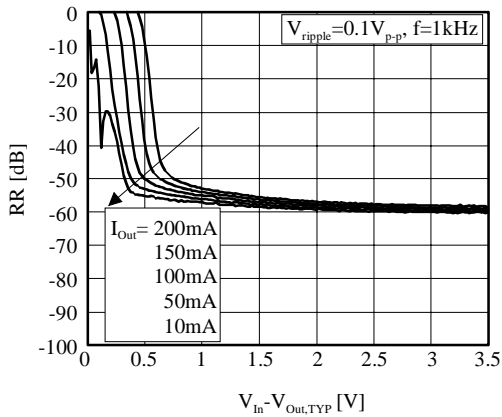

■ RR vs Frequency (TK68112AMF/M5/S2)

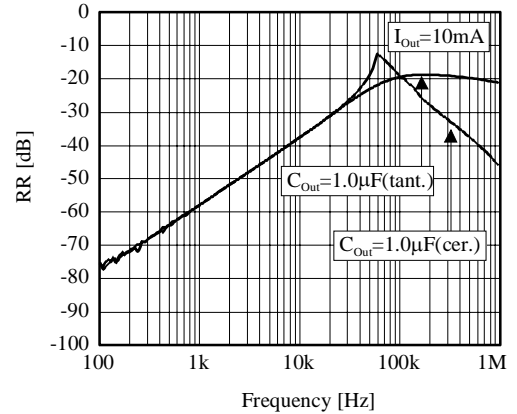

■ RR vs  $V_{In}$  (TK68128AMF/M5/S2)

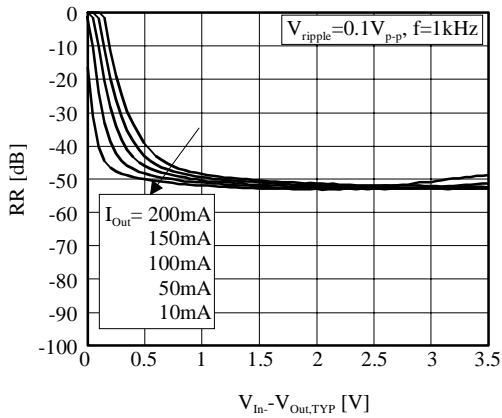

■ RR vs Frequency (TK68128AMF/M5/S2)

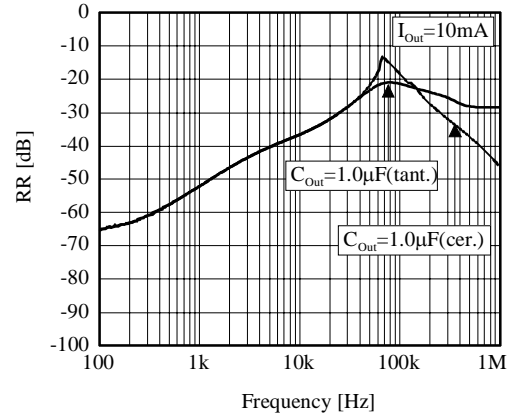

■ RR vs  $V_{In}$  (TK68142AMF/M5/S2)

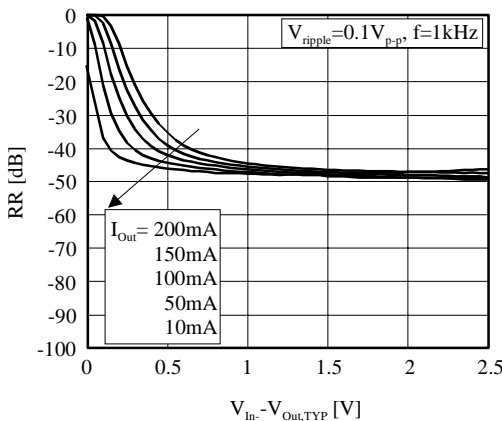

■ RR vs Frequency (TK68142AMF/M5/S2)

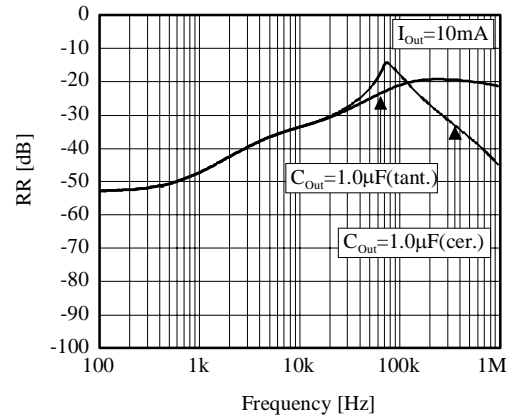

■ RR vs Frequency (TK68112AMF/M5/S2)

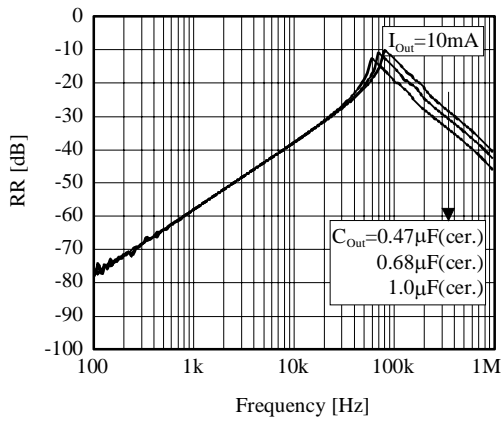

The ripple rejection (RR) characteristic depends on the characteristic and the capacitance value of the capacitor connected to the output side. The RR characteristic of 50kHz or more varies greatly with the capacitor on the output side and PCB pattern. If necessary, please confirm stability of your design.

■ RR vs Frequency (TK68128AMF/M5/S2)

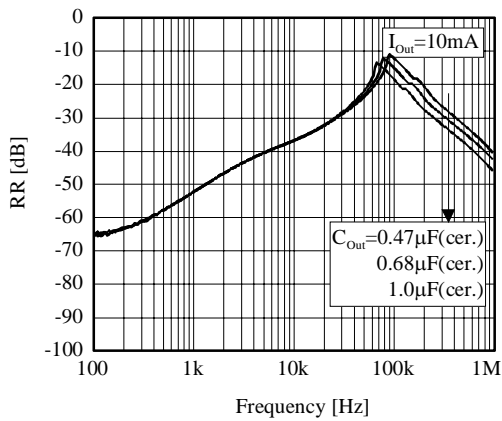

■ RR vs Frequency (TK68142AMF/M5/S2)

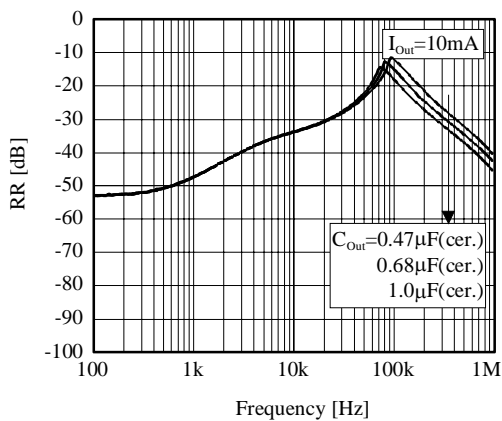

■  $V_{Noise}$  vs  $V_{In}$  (TK68112AMF/M5/S2)

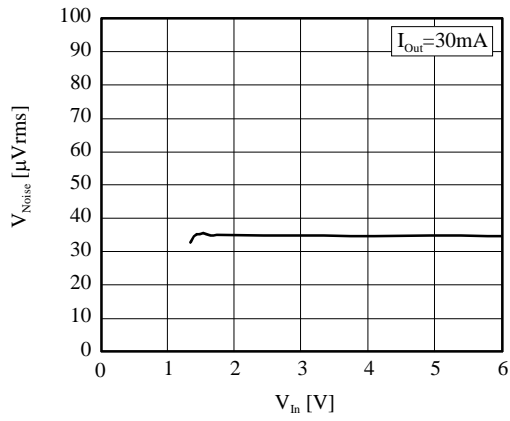

■  $V_{Noise}$  vs  $I_{Out}$  (TK68112AMF/M5/S2)

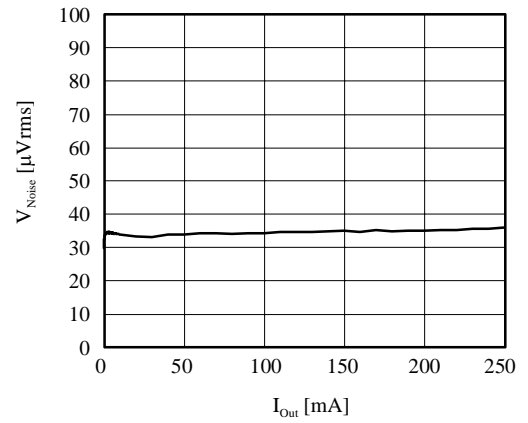

■  $V_{Noise}$  vs  $V_{In}$  (TK68128AMF/M5/S2)

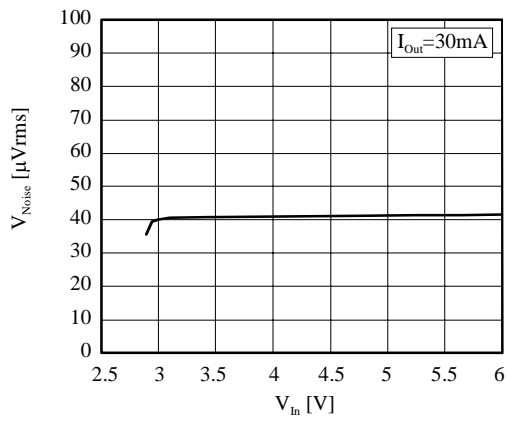

■  $V_{Noise}$  vs  $I_{Out}$  (TK68128AMF/M5/S2)

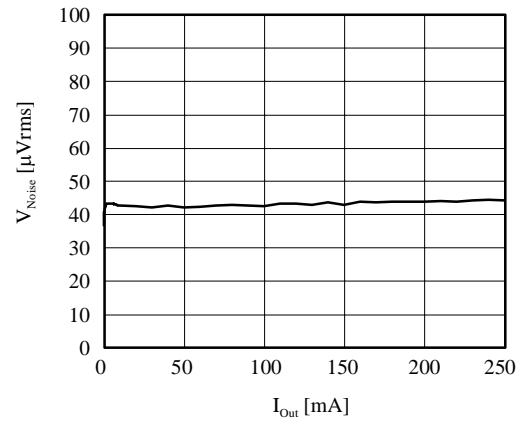

■  $V_{Noise}$  vs  $V_{In}$  (TK68142AMF/M5/S2)

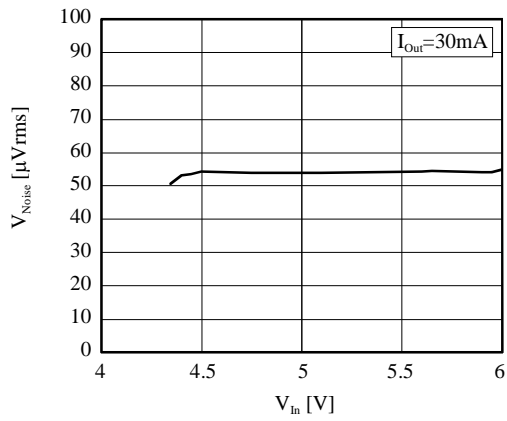

■  $V_{Noise}$  vs  $I_{Out}$  (TK68142AMF/M5/S2)

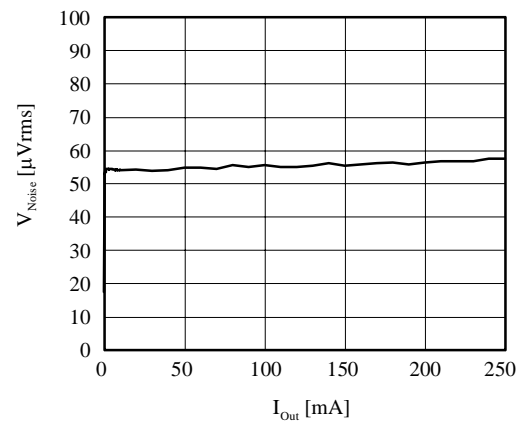

■  $V_{\text{Noise}}$  vs  $V_{\text{Out}}$  (TK681xxAMF/M5/S2)

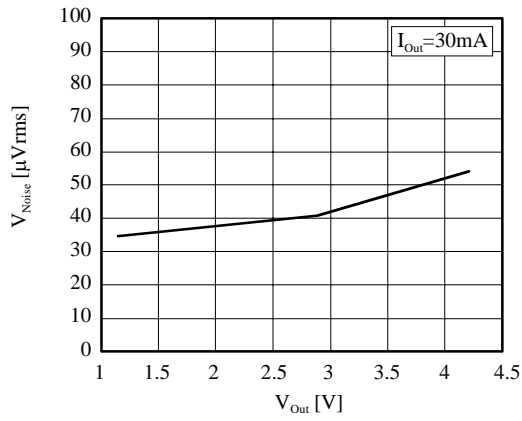

■  $V_{\text{Noise}}$  vs Frequency (TK68112AMF/M5/S2)

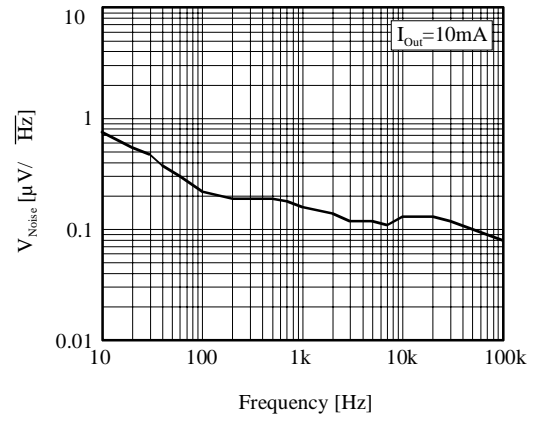

■  $V_{\text{Noise}}$  vs Frequency (TK68128AMF/M5/S2)

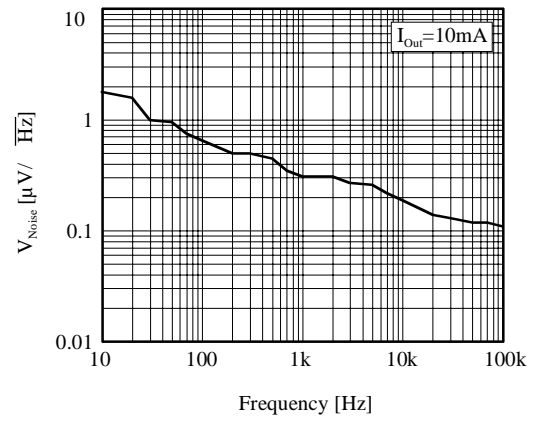

■  $V_{\text{Noise}}$  vs Frequency (TK68142AMF/M5/S2)

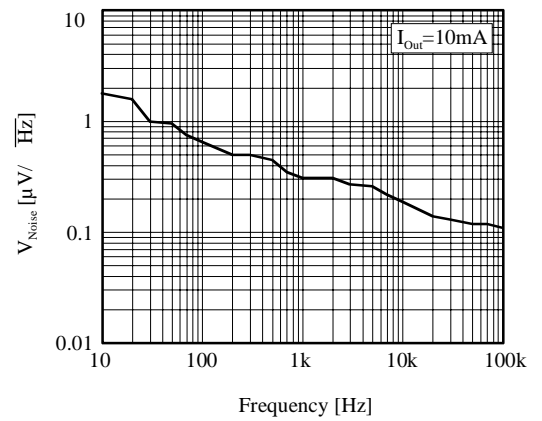

**10-3. TRANSIENT CHARACTERISTICS**

■ Line Transient (TK68112AMF/M5/S2)

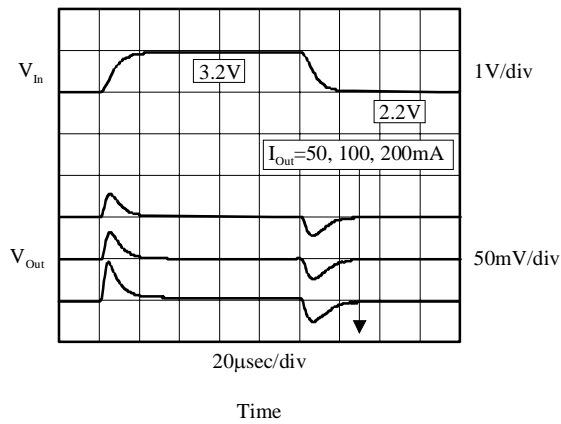

■ Load Transient ( $I_{out} = 5 \leftrightarrow 100\text{mA}$ ) (TK68112AMF/M5/S2)

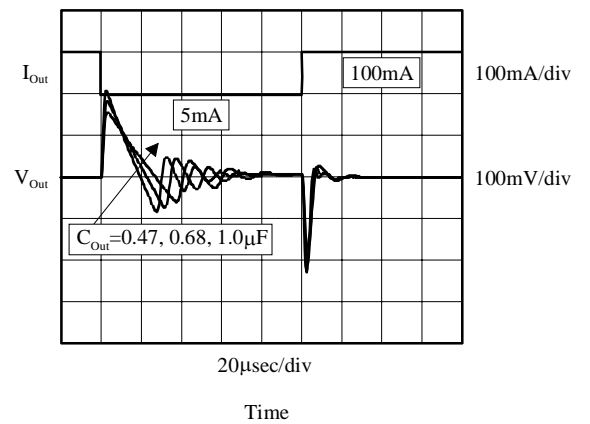

■ Line Transient (TK68128AMF/M5/S2)

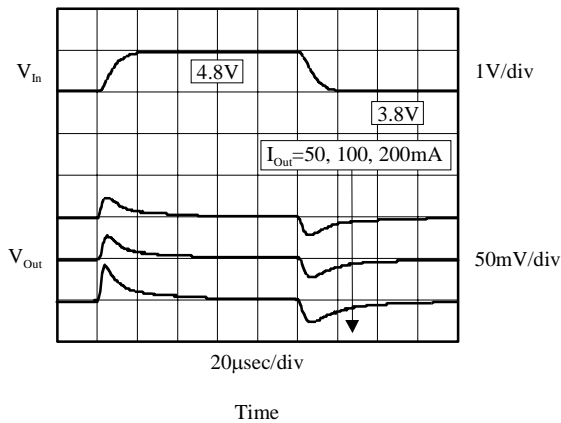

■ Load Transient ( $I_{out} = 5 \leftrightarrow 100\text{mA}$ ) (TK68128AMF/M5/S2)

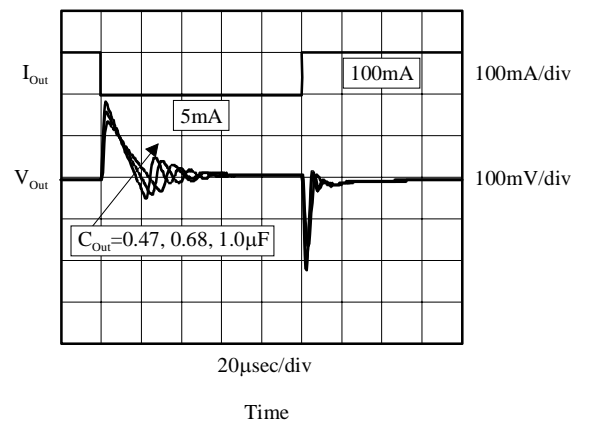

■ Line Transient (TK68142AMF/M5/S2)

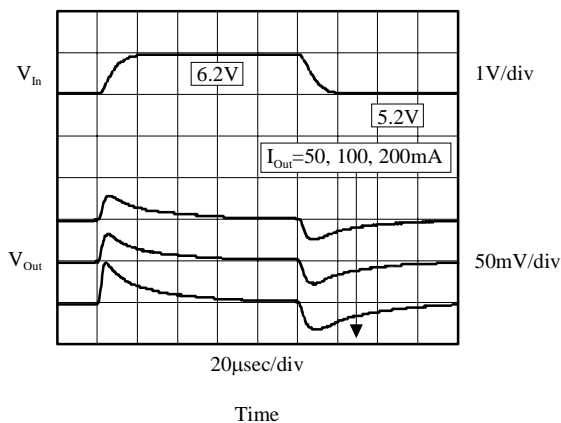

■ Load Transient ( $I_{out} = 5 \leftrightarrow 100\text{mA}$ ) (TK68142AMF/M5/S2)

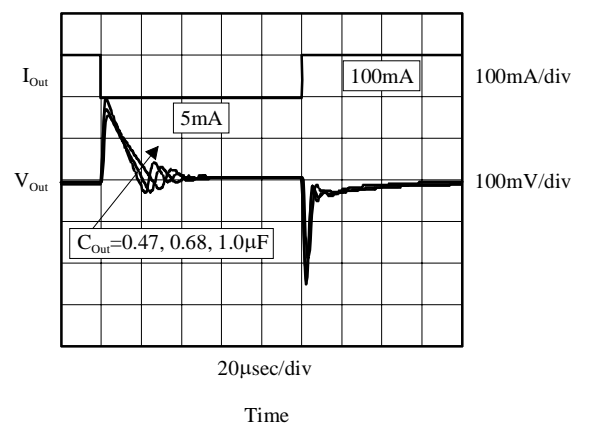

■ Load Transient ( $I_{Out}=0$  or  $5 \leftrightarrow 100\text{mA}$ )  
(TK68112AMF/M5/S2)

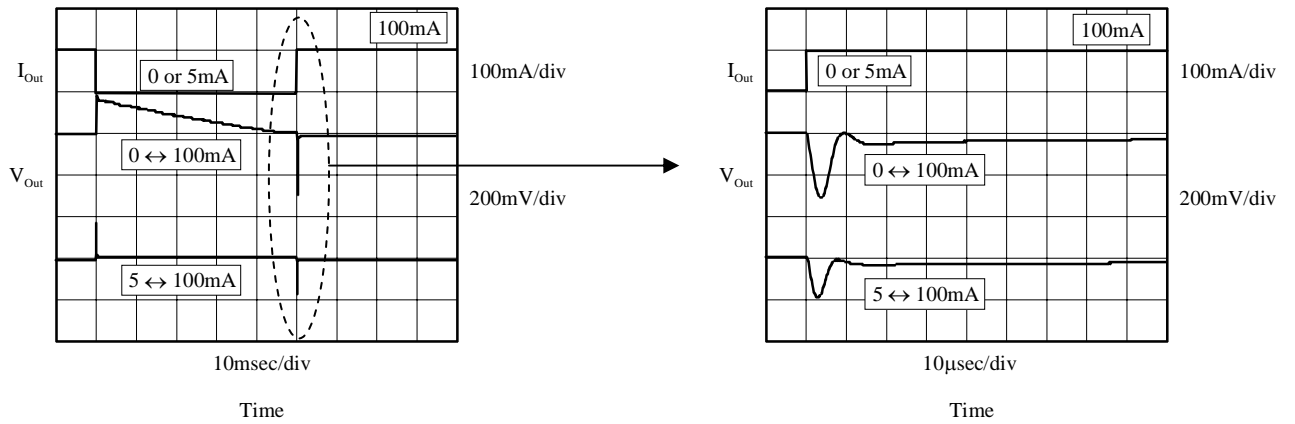

■ Load Transient ( $I_{Out}=0$  or  $5 \leftrightarrow 100\text{mA}$ )  
(TK68128AMF/M5/S2)

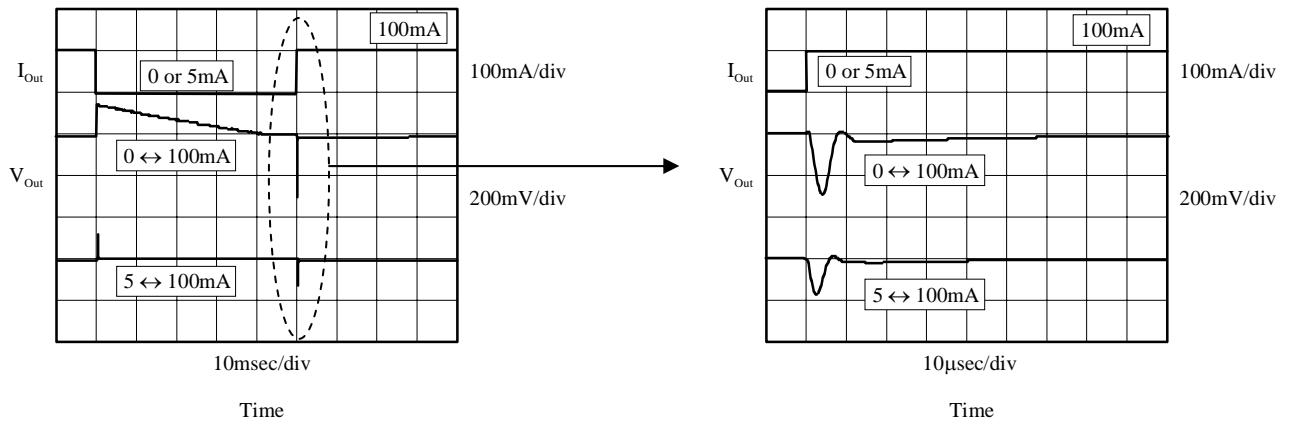

■ Load Transient ( $I_{Out}=0$  or  $5 \leftrightarrow 100\text{mA}$ )  
(TK68142AMF/M5/S2)

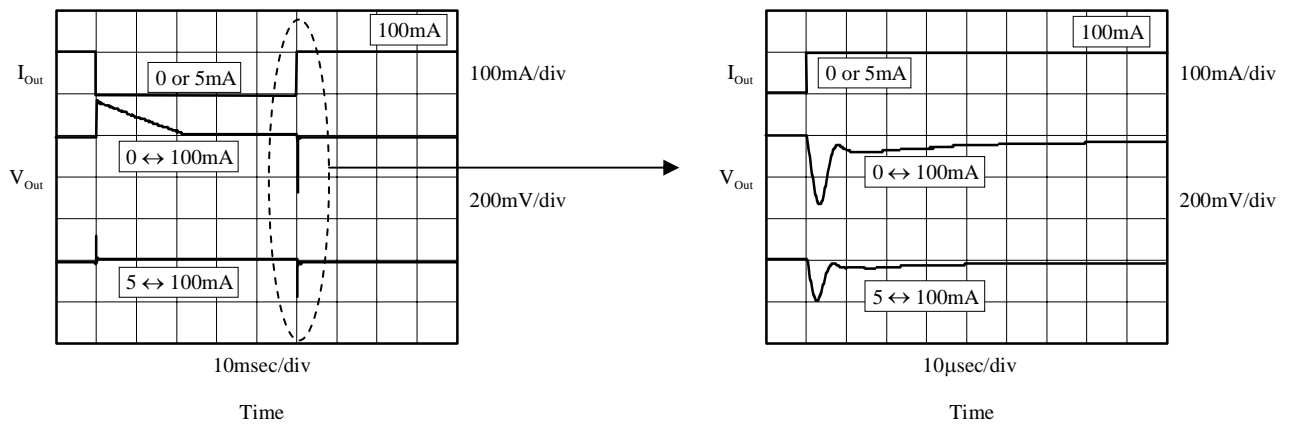

■ On/Off Transient ( $V_{Cont}=0 \rightarrow 1.2V$ )  
(TK68112AMF/M5/S2)

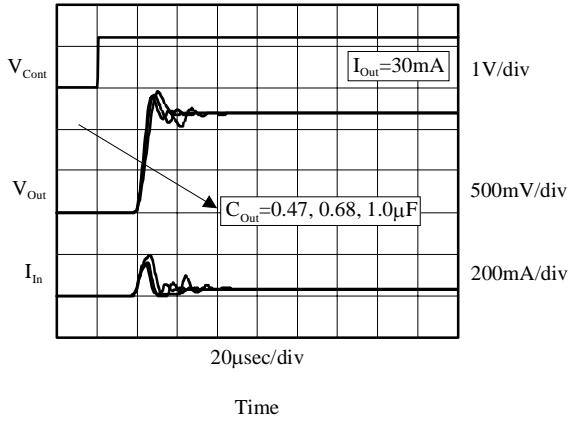

■ On/Off Transient ( $V_{Cont}=1.2 \rightarrow 0V$ )  
(TK68112AMF/M5/S2)

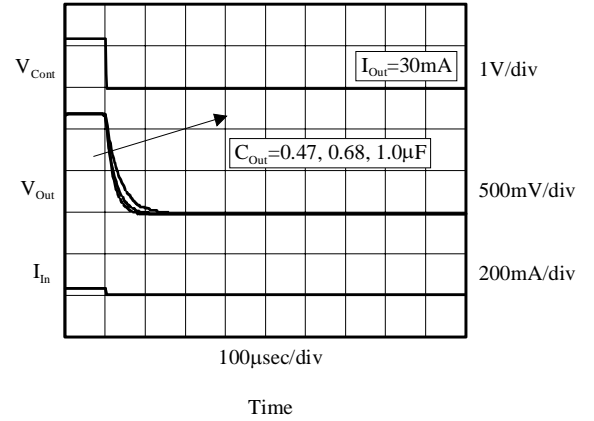

■ On/Off Transient ( $V_{Cont}=0 \rightarrow 1.2V$ )  
(TK68128AMF/M5/S2)

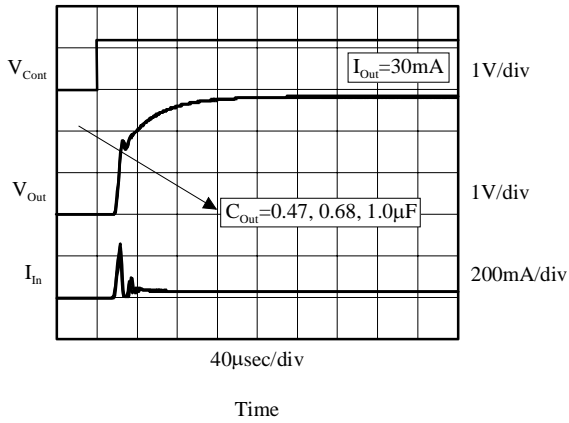

■ On/Off Transient ( $V_{Cont}=1.2 \rightarrow 0V$ )  
(TK68128AMF/M5/S2)

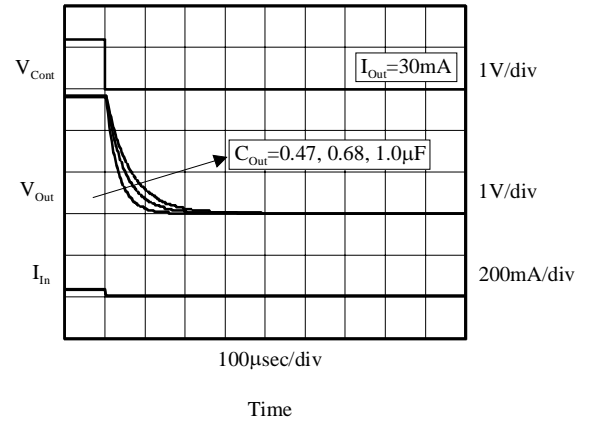

■ On/Off Transient ( $V_{Cont}=0 \rightarrow 1.2V$ )  
(TK68142AMF/M5/S2)

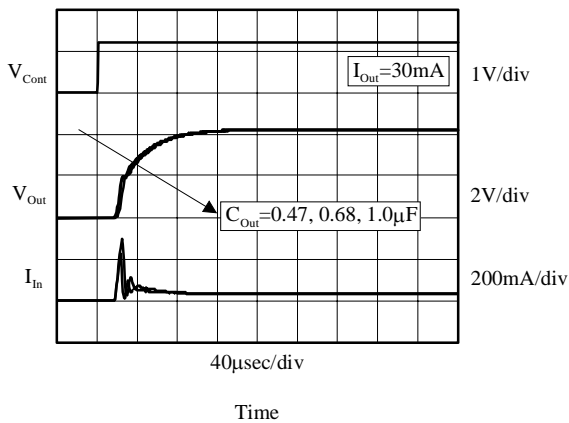

■ On/Off Transient ( $V_{Cont}=1.2 \rightarrow 0V$ )  
(TK68142AMF/M5/S2)

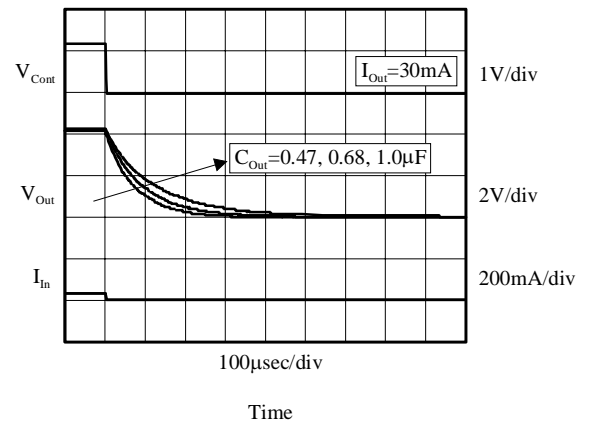

**11. PIN DESCRIPTION**

Pin No.			Pin Description	Internal Equivalent Circuit	Description
TK681xxAMF	TK681xxAM5	TK681xxAS2			
2	2, 5	2	GND		GND Terminal
3	6	3	V <sub>Cont</sub>		Control Terminal $V_{Cont} > 1.2V$ : On $V_{Cont} < 0.2V$ : Off The pull-down resistor (about 1.65MΩ) is built-in.
1	3	5	V <sub>Out</sub>		Output Terminal
4	1	1	V <sub>In</sub>		Input Terminal
	4	4	NC		No Connected

**12. APPLICATIONS INFORMATION**

**12-1. External Capacitor**

General linear regulators require input capacitor and output capacitor in order to maintain the regulator's loop stability.

The TK681xxAMF/M5/S2 provides stable operation without input capacitor and output capacitor.

Refer to the following data that measured without external capacitor.

The other electrical characteristics are equal to using external capacitor.

Transient characteristics (influence of load deviation) improve by using output capacitor (see the "Load Transient" on page 16).

Because a situation changes with each application, please confirm to operation in your design.

■ RR vs Frequency (TK68112AMF/M5/S2)

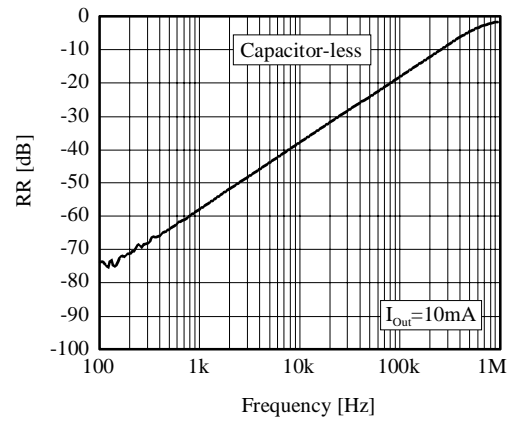

■ RR vs Frequency (TK68128AMF/M5/S2)

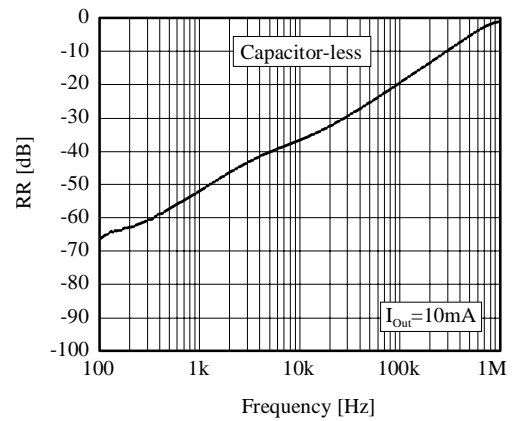

■ RR vs Frequency (TK68142AMF/M5/S2)

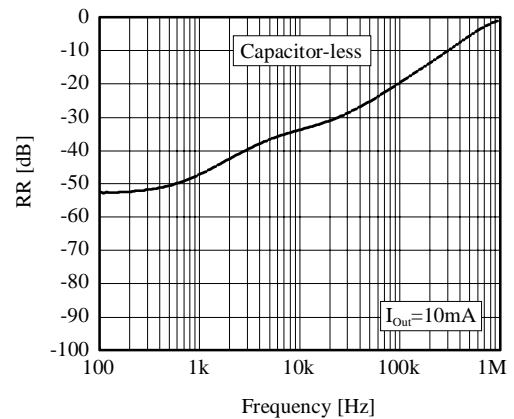

■  $V_{Noise}$  vs  $I_{Out}$  (TK68112AMF/M5/S2)

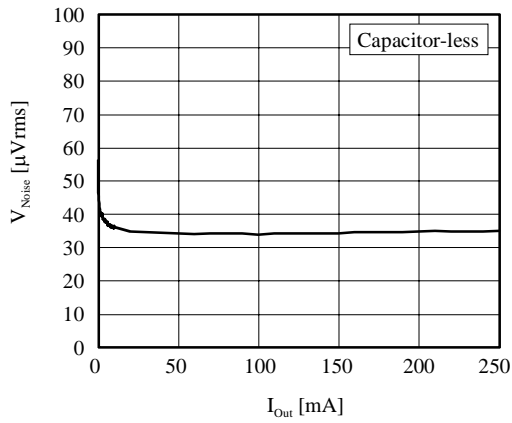

■ Load Transient ( $I_{Out}=5 \rightarrow 100mA$ ) (TK68112AMF/M5/S2)

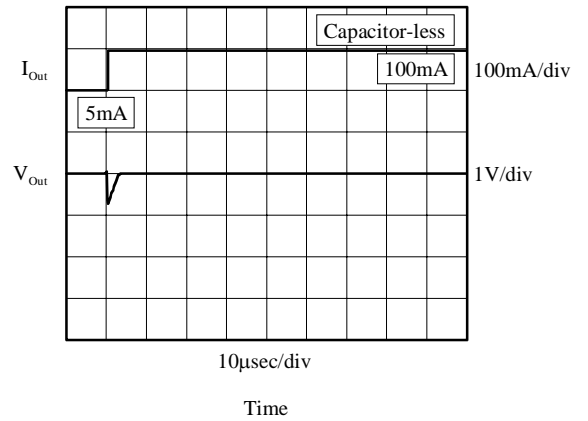

■  $V_{Noise}$  vs  $I_{Out}$  (TK68128AMF/M5/S2)

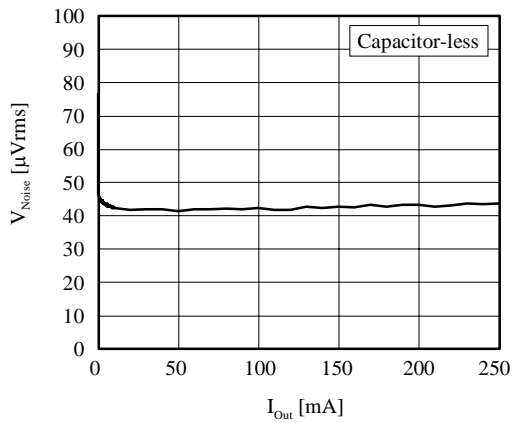

■ Load Transient ( $I_{Out}=5 \rightarrow 100mA$ ) (TK68128AMF/M5/S2)

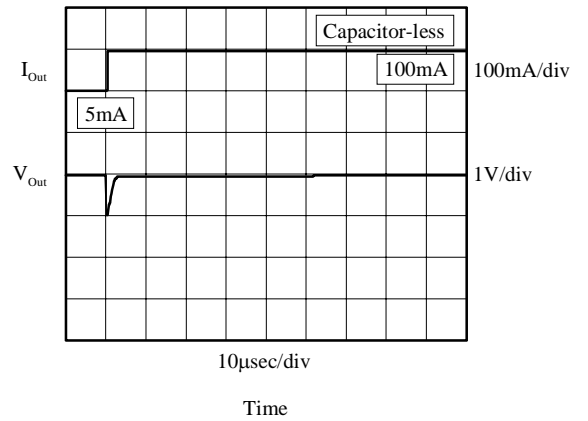

■  $V_{Noise}$  vs  $I_{Out}$  (TK68142AMF/M5/S2)

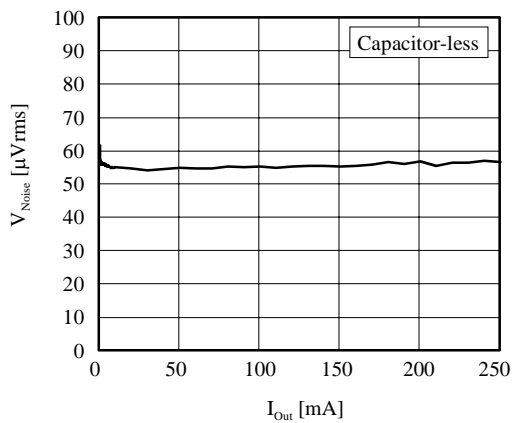

■ Load Transient ( $I_{Out}=5 \rightarrow 100mA$ ) (TK68142AMF/M5/S2)

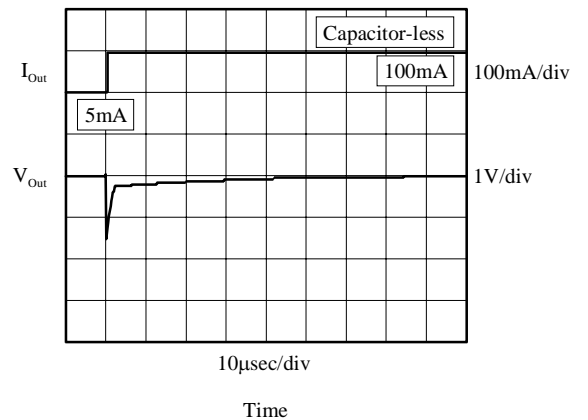

■ On/Off Transient ( $V_{Cont}=0 \rightarrow 1.2V$ )  
(TK68112AMF/M5/S2)

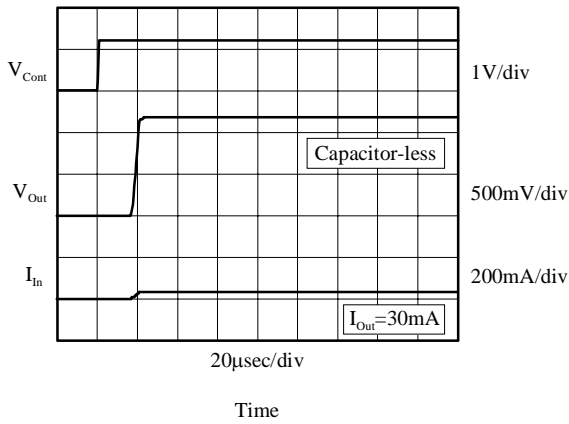

■ On/Off Transient ( $V_{Cont}=1.2 \rightarrow 0V$ )  
(TK68112AMF/M5/S2)

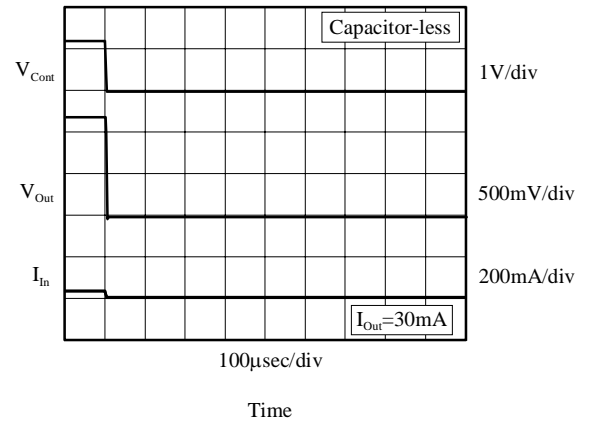

■ On/Off Transient ( $V_{Cont}=0 \rightarrow 1.2V$ )  
(TK68128AMF/M5/S2)

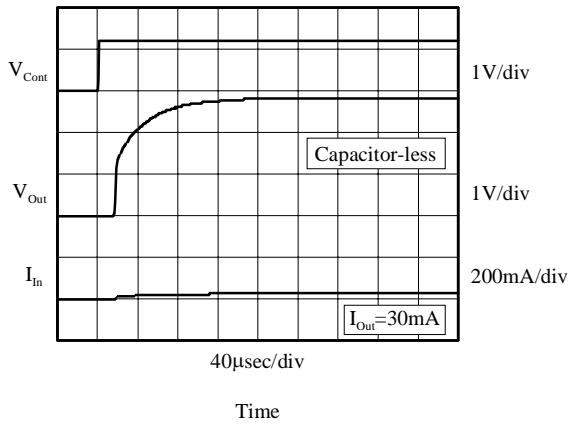

■ On/Off Transient ( $V_{Cont}=1.2 \rightarrow 0V$ )  
(TK68128AMF/M5/S2)

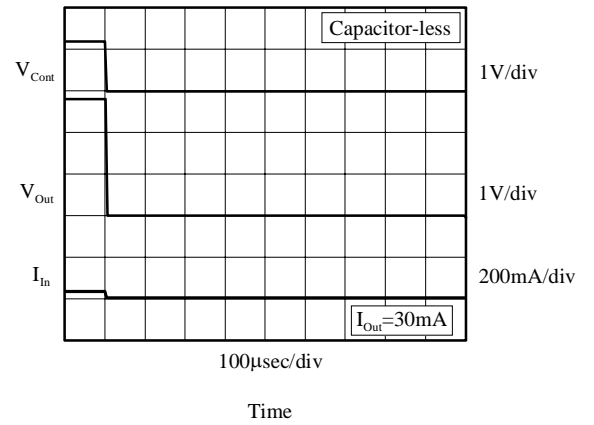

■ On/Off Transient ( $V_{Cont}=0 \rightarrow 1.2V$ )  
(TK68142AMF/M5/S2)

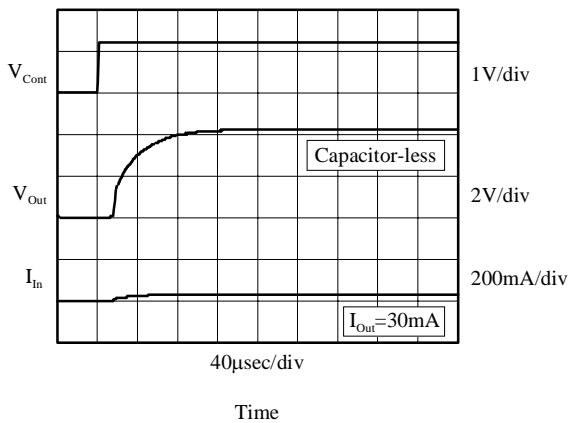

■ On/Off Transient ( $V_{Cont}=1.2 \rightarrow 0V$ )  
(TK68142AMF/M5/S2)

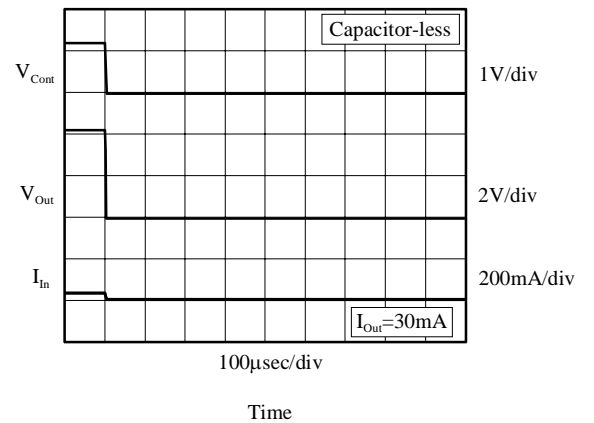

**12-2. Layout**

☒12-1: Layout example (TK681xxAMF)

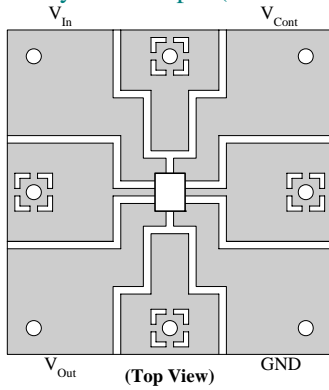

PCB Material: Glass epoxy  
Size: 30mm×30mm×1mm

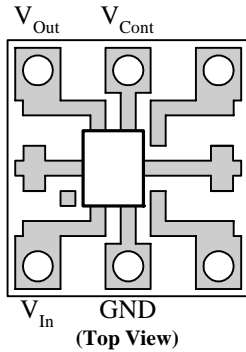

PCB Material: Glass epoxy  
Size: 7mm×8mm×0.8mm

☒12-2: Layout example (TK681xxAM5)

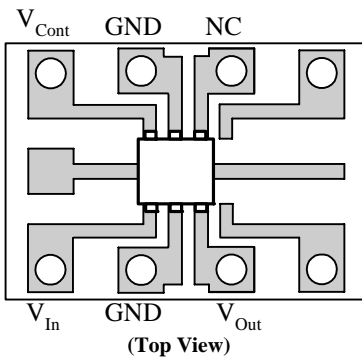

PCB Material: Glass epoxy  
Size : 10mm×7mm×0.8mm

☒12-3: Layout example (TK681xxAS2)

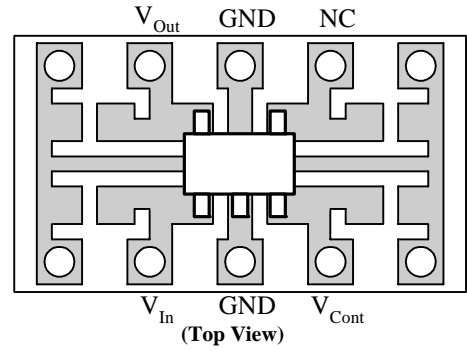

PCB Material: Glass epoxy  
Size: 12mm×7mm×0.8mm

Please do derating with 3.2mW/°C(PCB size: 7mm×8mm×0.8mm), 7.2mW/°C(PCB size: 30mm×30mm×1mm), at P<sub>D</sub>=400mW(PCB size: 7mm×8mm×0.8mm), 900mW (PCB size: 30mm×30mm×1mm), and 25°C or more (TK681xxAMF). Please do derating with 4mW/°C at P<sub>D</sub>=500mW, and 25°C or more (TK681xxAM5/S2).

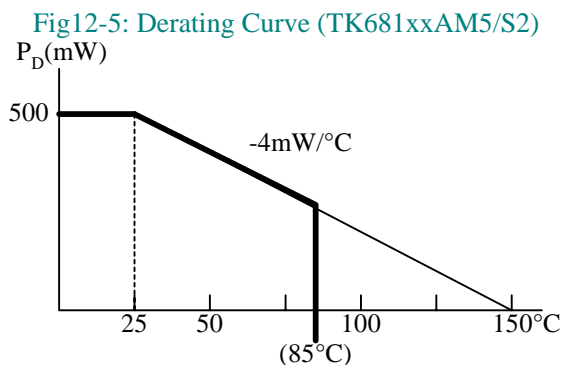
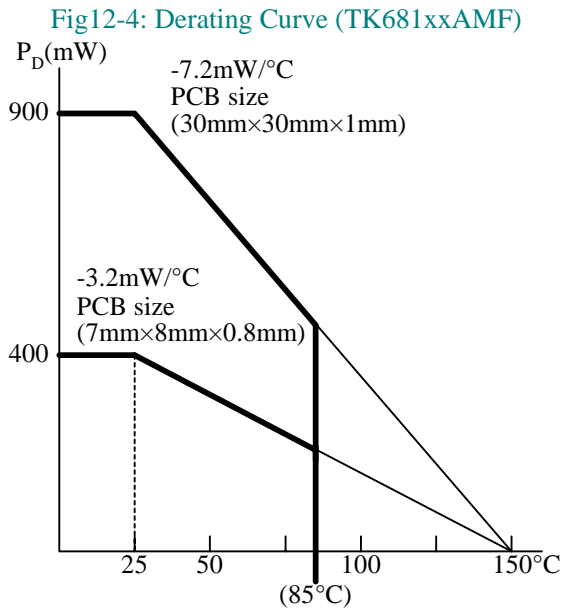

The package loss is limited at the temperature that the internal temperature sensor works (about 150°C). Therefore, the package loss is assumed to be an internal limitation. There is no heat radiation characteristic of the package unit assumed because of its small size. Heat is carried away from the device by being mounted on the PCB. This value is directly effected by the material and the copper pattern etc. of the PCB. The losses are approximately 400mW (TK681xxAMF), 500mW (TK681xxAM5/S5). Enduring these losses becomes possible in a lot of applications operating at 25°C.

The overheating protection circuit operates when the junction temperature reaches 150°C (this happens when the regulator is dissipating excessive power, outside

temperature is high, or heat radiation is bad). The output current and the output voltage will drop when the protection circuit operates. However, operation begins again as soon as the output voltage drops and the temperature of the chip decreases.

**How to determine the thermal resistance when mounted on PCB**

The thermal resistance when mounted is expressed as follows:

$$T_j = \theta_{ja} \times P_D + T_a$$

T<sub>j</sub> of IC is set around 150°C. P<sub>D</sub> is the value when the thermal sensor is activated.

If the ambient temperature is 25°C, then:

$$150 = \theta_{ja} \times P_D + 25$$

$$\theta_{ja} = 125 / P_D \text{ (}^\circ\text{C / mW)}$$

**P<sub>D</sub> is easily calculated.**

A simple way to determine P<sub>D</sub> is to calculate V<sub>in</sub>×I<sub>In</sub> when the output side is shorted. Input current gradually falls as output voltage rises after working thermal shutdown. You should use the value when thermal equilibrium is reached.

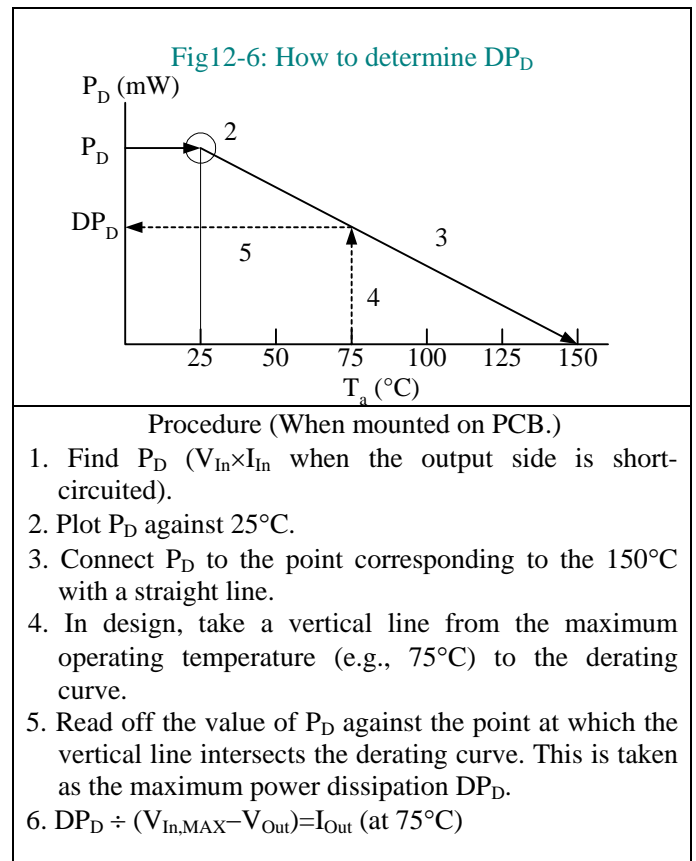

The maximum output current at the highest operating temperature will be I<sub>Out</sub> ≅ DP<sub>D</sub> ÷ (V<sub>In,MAX</sub>-V<sub>Out</sub>). Please use the device at low temperature with better radiation. The lower temperature provides better quality.

### 12-3. On/Off Control

It is recommended to turn the regulator Off when the circuit following the regulator is not operating. A design with little electric power loss can be implemented. We recommend the use of the On/Off control of the regulator without using a high side switch to provide an output from the regulator. A highly accurate output voltage with low voltage drop is obtained.

Because the control current is small, it is possible to control it directly by CMOS logic.

Fig12-7: The use of On/Off control

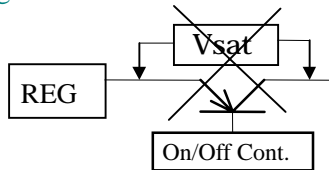

Control Terminal Voltage ( $V_{Cont}$ )	On/Off State
$V_{Cont} > 1.2V$	On
$V_{Cont} < 0.2V$	Off

#### Parallel Connected On/Off Control

Fig12-8: The example of parallel connected IC

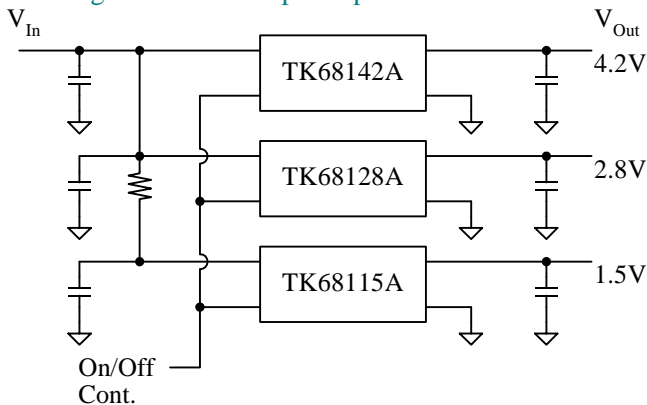

The above figure is multiple regulators being controlled by a single On/Off control signal. There is concern of overheating, because the power loss of the low voltage side IC (TK68115AMF/M5/S2) is large. The series resistor (R) is put in the input line of the low output voltage regulator in order to prevent over-dissipation. The voltage dropped across the resistor reduces the large input-to-output voltage across the regulator, reducing the power dissipation in the device. When the thermal sensor works, a decrease of the output voltage, oscillation, etc. may be observed.

## 12-4. Definition of term

### Characteristics

#### ◆ Output Voltage ( $V_{Out}$ )

The output voltage is specified with  $V_{In}=(V_{OutTYP}+1V)$  and  $I_{Out}=5mA$ .

#### ◆ Maximum Output Current ( $I_{Out, MAX}$ )

The rated output current is specified under the condition where the output voltage drops to 90% of the value specified with  $I_{Out}=5mA$ . The input voltage is set to  $V_{OutTYP}+1V$  and the current is pulsed to minimize temperature effect.

#### ◆ Dropout Voltage ( $V_{Drop}$ )

The dropout voltage is the difference between the input voltage and the output voltage at which point the regulator starts to fall out of regulation. Below this value, the output voltage will fall as the input voltage is reduced. It is dependent upon the output voltage, the load current, and the junction temperature.

#### ◆ Line Regulation (LinReg)

Line regulation is the ability of the regulator to maintain a constant output voltage as the input voltage changes. The line regulation is specified as the input voltage is changed from  $V_{In}=V_{Out,TYP}+1V$  to  $V_{In}=6V$ . It is a pulse measurement to minimize temperature effect.

#### ◆ Load Regulation (LoaReg)

Load regulation is the ability of the regulator to maintain a constant output voltage as the load current changes. It is a pulsed measurement to minimize temperature effects with the input voltage set to  $V_{In}=V_{Out,TYP}+1V$ . The load regulation is specified under an output current step condition of 1mA to 50mA.

#### ◆ Ripple Rejection (RR)

Ripple rejection is the ability of the regulator to attenuate the ripple content of the input voltage at the output. It is specified with 500mV<sub>P-P</sub>, 1kHz super-imposed on the input voltage, where  $V_{In}=V_{Out,TYP}+1.5V$ . Ripple rejection is the ratio of the ripple content of the output vs. input and is expressed in dB.

#### ◆ Standby Current ( $I_{Standby}$ )

Standby current is the current which flows into the regulator when the output is turned off by the control function ( $V_{Cont}=0V$ ).

### Protections

#### ◆ Over Current Sensor

The over current sensor protects the device when there is excessive output current. It also protects the device if the output is accidentally connected to ground.

#### ◆ Thermal Sensor

The thermal sensor protects the device in case the junction temperature exceeds the safe value ( $T_j=150^{\circ}C$ ). This temperature rise can be caused by external heat, excessive power dissipation caused by large input to output voltage drops, or excessive output current. The regulator will shut off when the temperature exceeds the safe value. As the junction temperatures decrease, the regulator will begin to operate again. Under sustained fault conditions, the regulator output will oscillate as the device turns off then resets. Damage may occur to the device under extreme fault.

Please prevent the loss of the regulator when this protection operates, by reducing the input voltage or providing better heat efficiency.

#### ◆ ESD

MM : 200pF 0Ω 150V or more

HBM : 100pF 1.5kΩ 2000V or more

**13. PACKAGE OUTLINE**

■ 4-Lead-Small Outline Non-Leaded Package with Heat Sink

: HSON1214-4

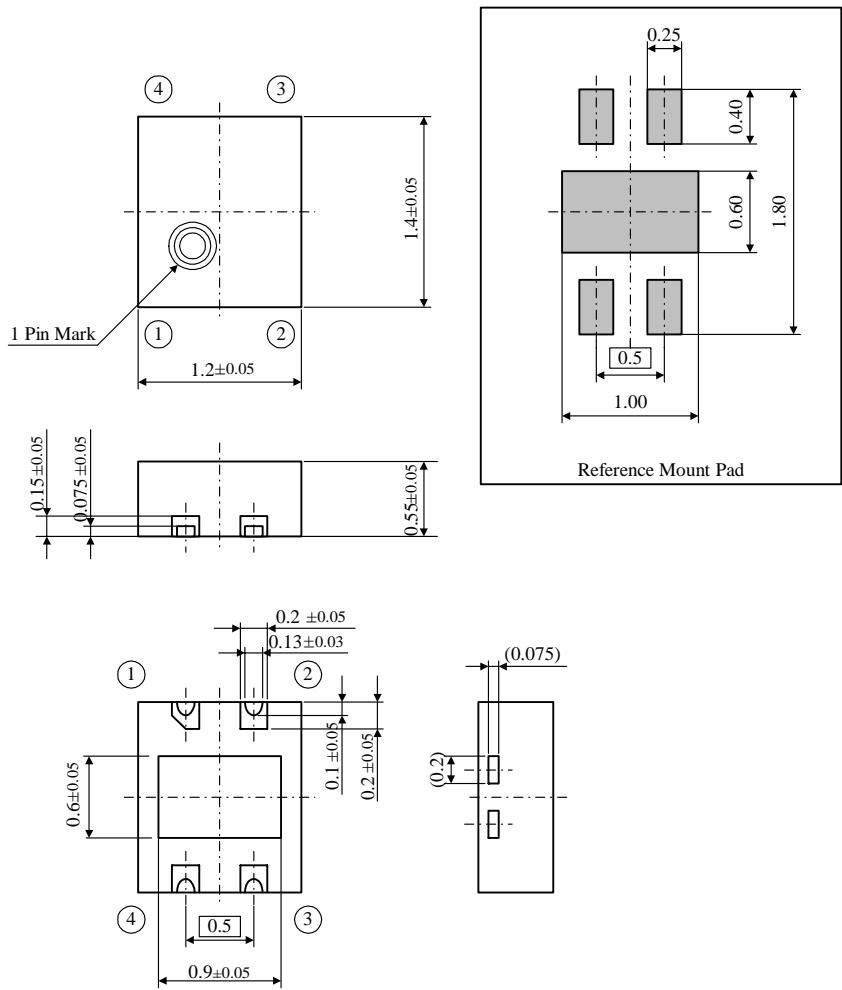

Unit : mm

**Package Structure and Others**

- Package Material : Epoxy Resin
- Terminal Material : Copper Alloy
- Terminal Finish : Ni/Pd/Au

**Marking**

Part Number	Marking Code	Part Number	Marking Code	Part Number	Marking Code
TK68112AMF	B12	TK68127AMF	B27	TK68132AMF	B32
TK68113AMF	B13	TK68128AMF	B28	TK68133AMF	B33
TK68115AMF	B15	TK68101AMF	B01	TK68135AMF	B35
TK68118AMF	B18	TK68129AMF	B29	TK68140AMF	B40
TK68125AMF	B25	TK68130AMF	B30		
TK68126AMF	B26	TK68131AMF	B31		

■ 6-Lead-Small Outline Non-Leaded Package : SON2017-6

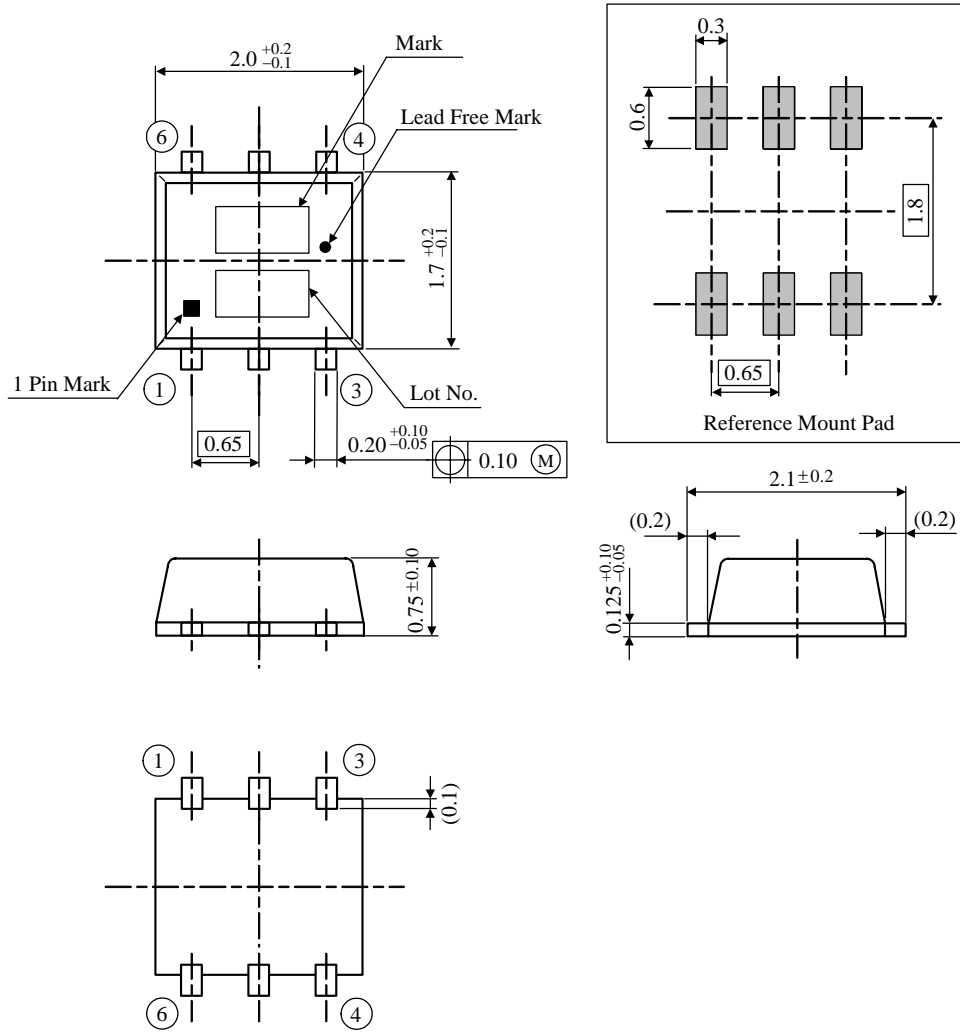

Unit : mm

**Package Structure and Others**

Package Material	: Epoxy Resin	Mark Method	: Laser
Terminal Material	: Copper Alloy	County of Origin	: Japan
Terminal Finish	: Lead Free Solder Plating(5~15µm)	Mass	: 0.0066g
Solder Composition	: Sn-2.5Ag		

**Marking**

Part Number	Marking Code	Part Number	Marking Code	Part Number	Marking Code
TK68112AM5	J12	TK68127AM5	J27	TK68132AM5	J32
TK68113AM5	J13	TK68128AM5	J28	TK68133AM5	J33
TK68115AM5	J15	TK68101AM5	J01	TK68135AM5	J35
TK68118AM5	J18	TK68129AM5	J29	TK68140AM5	J40
TK68125AM5	J25	TK68130AM5	J30		
TK68126AM5	J26	TK68131AM5	J31		

■ 5-Lead-Surface Mount Discrete Package : SOT23-5

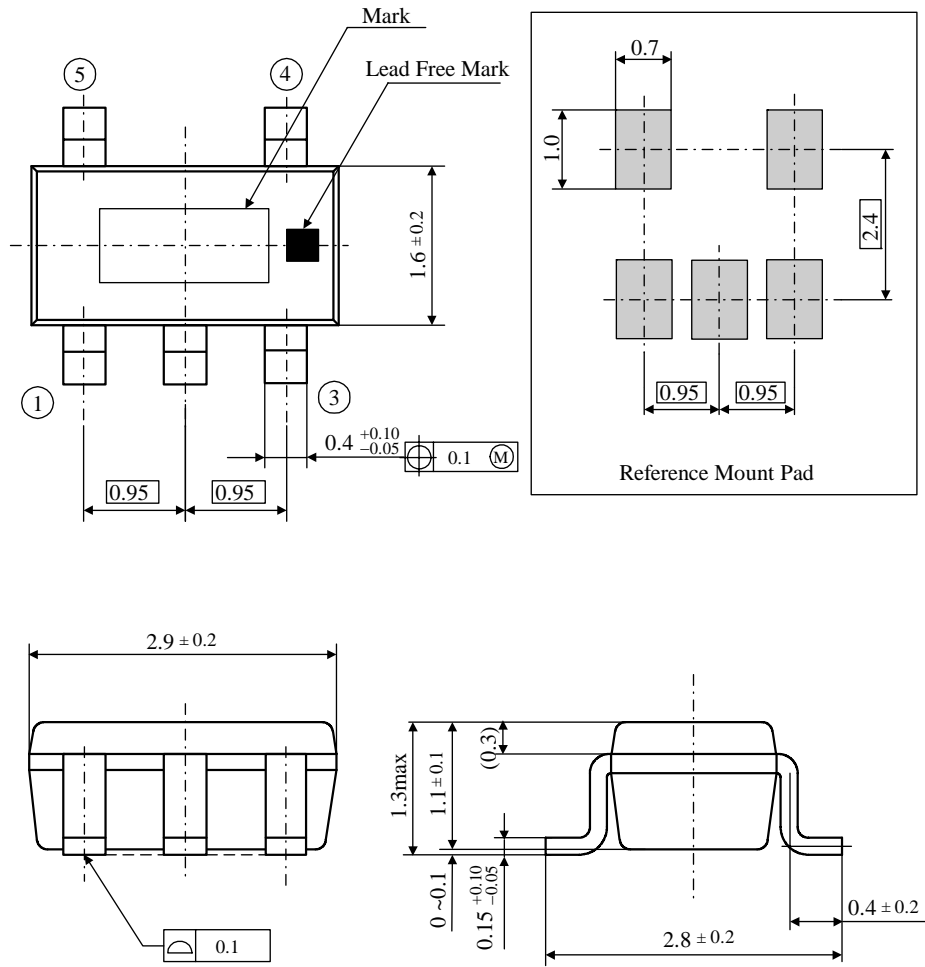

Unit : mm

**Package Structure and Others**

Package Material	: Epoxy Resin	Mark Method	: Laser
Terminal Material	: Copper Alloy	Country of Origin	: Japan
Terminal Finish	: Lead Free Solder Plating(5~15µm)	Mass	: 0.016g
Solder Composition	: Sn-2.5Ag		

**Marking**

Part Number	Marking Code	Part Number	Marking Code	Part Number	Marking Code
TK68112AS2	N12	TK68127AS2	N27	TK68132AS2	N32
TK68113AS2	N13	TK68128AS2	N28	TK68133AS2	N33
TK68115AS2	N15	TK68101AS2	N01	TK68135AS2	N35
TK68118AS2	N18	TK68129AS2	N29	TK68140AS2	N40
TK68125AS2	N25	TK68130AS2	N30		
TK68126AS2	N26	TK68131AS2	N31		

**14. NOTES**

■ Please be sure that you carefully discuss your planned purchase with our office if you intend to use the products in this application manual under conditions where particularly extreme standards of reliability are required, or if you intend to use products for applications other than those listed in this application manual.

- Power drive products for automobile, ship or aircraft transport systems; steering and navigation systems, emergency signal communications systems, and any system other than those mentioned above which include electronic sensors, measuring, or display devices, and which could cause major damage to life, limb or property if misused or failure to function.

- Medical devices for measuring blood pressure, pulse, etc., treatment units such as coronary pacemakers and heat treatment units, and devices such as artificial organs and artificial limb systems which augment physiological functions.

- Electrical instruments, equipment or systems used in disaster or crime prevention.

■ Semiconductors, by nature, may fail or malfunction in spite of our devotion to improve product quality and reliability. We urge you to take every possible precaution against physical injuries, fire or other damages which may cause failure of our semiconductor products by taking appropriate measures, including a reasonable safety margin, malfunction preventive practices and fire-proofing when designing your products.

■ This application manual is effective from Dec. 2006. Note that the contents are subject to change or discontinuation without notice. When placing orders, please confirm specifications and delivery condition in writing.

■ TOKO is not responsible for any problems nor for any infringement of third party patents or any other intellectual property rights that may arise from the use or method of use of the products listed in this application manual. Moreover, this application manual does not signify that TOKO agrees implicitly or explicitly to license any patent rights or other intellectual property rights which it holds.

■ None of the ozone depleting substances(ODS) under the Montreal Protocol are used in our manufacturing process.

**15. OFFICES**

If you need more information on this product and other TOKO products, please contact us.

■ TOKO Inc. Headquarters  
 1-17, Higashi-yukigaya 2-chome, Ohta-ku, Tokyo,  
 145-8585, Japan  
 TEL: +81.3.3727.1161  
 FAX: +81.3.3727.1176 or +81.3.3727.1169  
 Web site: <http://www.toko.co.jp/>

■ TOKO America  
 Web site: <http://www.toko.com/>

■ TOKO Europe  
 Web site: <http://www.tokoeurope.com/>

■ TOKO Hong Kong  
 Web site: <http://www.toko.com.hk/>

■ TOKO Taiwan  
 Web site: <http://www.tokohc.com.tw/>

■ TOKO Singapore  
 Web site: <http://www.toko.com.sg/>

■ TOKO Seoul  
 Web site: <http://www.toko.co.kr/>

■ TOKO Manila  
 Web site: <http://www.toko.com.ph/>

■ TOKO Brazil  
 Web site: <http://www.toko.com.br/>



**Semiconductor Division**

YOUR DISTRIBUTOR