

APPLICATION MANUAL

PWM switching regulator controller IC
TK11840L

CONTENTS

1 . DESCRIPTION	2
2 . FEATURES	2
3 . APPLICATIONS	2
4 . PIN CONFIGURATION	2
5 . PACKAGE OUTLINE	2
6 . BLOCK DIAGRAM	3
7 . ABSOLUTE MAXIMUM RATINGS	4
8 . ELECTRICAL CHARACTERISTICS	5
9 . TEST CIRCUIT	6
10 . TYPICAL CHARACTERISTICS	6
11 . CIRCUIT DESCRIPTION	8
12 . APPLICATIONS INFORMATION	13
13 . NOTES	15
14 . OFFICES	15



PWM switching regulator controller IC TK11840L

1. DESCRIPTION

The TK11840L is a step-up DC-DC converter that drives an external NPN power transistor using a constant frequency PWM architecture.

The IC works with a wide operating supply range (1.8V to 10V) and has an adjustable output.

The IC timing oscillator operating frequency is programmable and can be set up to 1MHz.

The TK11840L incorporates a soft-start circuit, which ensures that the output pulse width starts from 0 % duty cycle and builds up to its proper level gradually when the IC is first powered up.

The TK11840L also incorporates a short-circuit detection function of a timer-latch type.

2. FEATURES

- Operation from 1.8V to 10V supply.
- Adjustable output voltage.
- High speed adjustable OSC. (Up to 1MHz)
- Incorporates a soft start circuit.
- Incorporates a short circuit detection of a timer-latch.
- Totem-pole type output in which current is adjustable using an external resistor.(Pin 4)
- 1μA or less shutdown current.
- Low component count.
- Small 8 Pin SOT23L-8 package.

3. APPLICATIONS

- White LED Backlighting and Frontlighting.
- Step-up DC-DC Converters
- Mobile Communication Systems:
Cellular Phone,PHS,DSC,PDA
- Computer Peripherals Equipment
- Battery Powered System
- Portable Equipment

4. PIN CONFIGURATION

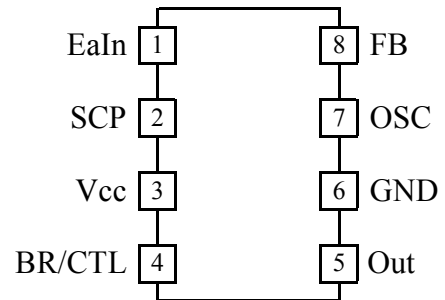

5. PACKAGE OUTLINE

■ SOT23L-8

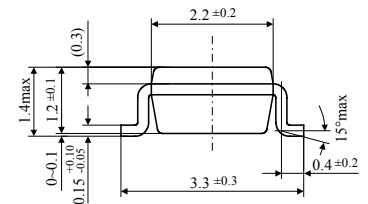
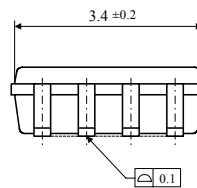
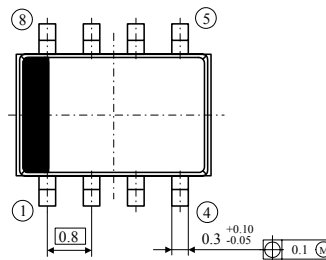

Unit : mm

6. BLOCK DIAGRAM

Pin No.	Symbol	Description
1	EaIn	Error amplifier inverting input Feed back input. Threshold voltage is 0.5V . Connect resistive divider tap to this pin.
2	SCP	Soft start and Short circuit detection Connect external capacitor Cscp to this pin.
3	V _{CC}	Power Supply Voltage Input
4	BR/CTL	Output current setting and shutdown
5	Out	Totem-Pole type Output Connect to base of external NPN switching transistor.
6	GND	Ground
7	OSC	Oscillation frequency setting pin Connect external capacitor Ct and resistor Rt to this pin.
8	FB	Error amplifier output Compensation pin for error amplifier. Connect capacitor Cfb from FB pin (pin 8) to GND.

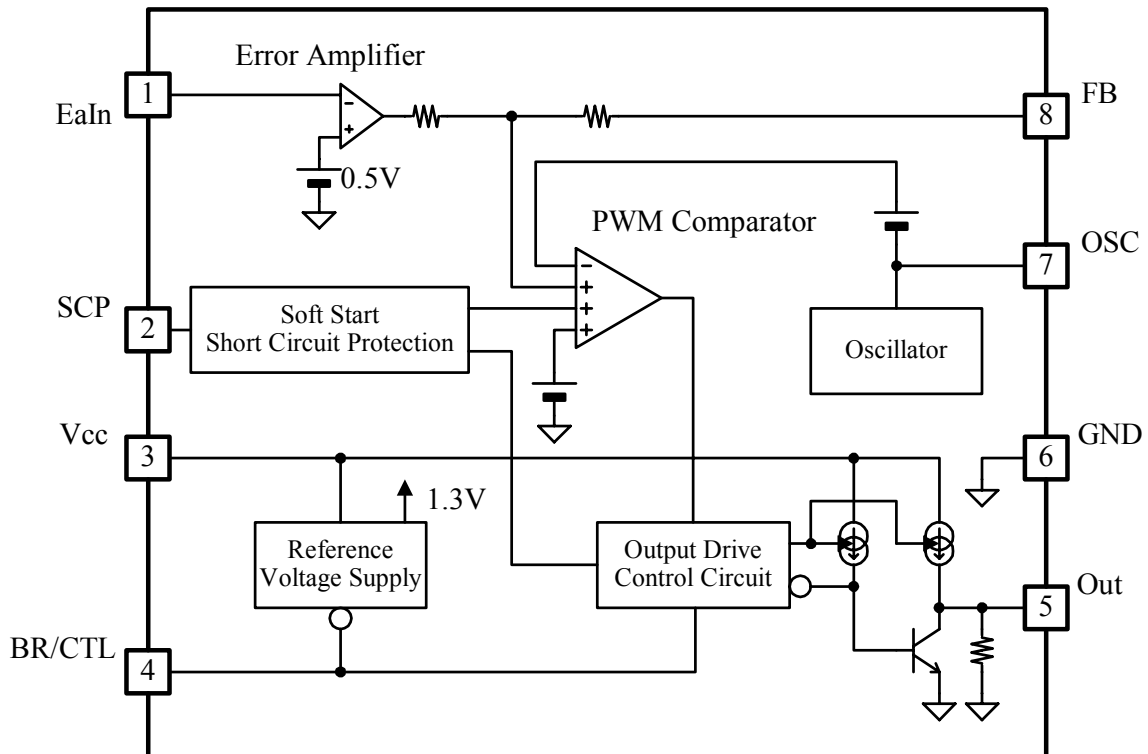

7. ABSOLUTE MAXIMUM RATINGS

T_a=25°C

Parameter	Symbol	Rating	Units	Conditions
Supply Voltage	V _{CC}	10	V	
Power Dissipation	P _D	400	mW	*
Storage Temperature Range	T _{stg}	-55 ~ +150	°C	
Operating Temperature Range	T _{OP}	-20 ~ +85	°C	
Maximum Operating Frequency	f _{MAX}	~ 1000	kHz	
Operating Voltage Range	V _{OP}	1.8 ~ 10	V	

* P_D must be decreased at rate of 3.2mW/°C for operation above 25°C.

8. ELECTRICAL CHARACTERISTICS

$V_{CC}=2V, T_a=25^{\circ}C$

Parameter	Symbol	Value			Units	Conditions	
		MIN	TYP	MAX			
Circuit to prevent malfunction at low input voltage							
Reset voltage	$V_{CC, Reset}$	-	-	0.9	V		
Threshold voltage	$V_{CC, On}$	1.1	1.3	1.5	V		
Soft start							
Charging current	I_{SS}	-1.8	-1.2	-0.84	μA	$V_{SCP}=0V$	
Threshold voltage	$V_{SS, TH}$	0.65	0.75	0.85	V		
Short circuit protection (S.C.P)							
Charging current	I_{SCP}	-1.8	-1.2	-0.84	μA	$V_{SCP}=0V$	
Threshold voltage	$V_{SCP, TH}$	0.65	0.75	0.85	V		
Oscillator							
Frequency	f_{OSC}	440	550	660	kHz	$R_t=3k\Omega, C_t=270pF$	
Frequency input stability	$f_{\Delta V}$	-	2	10	%	$V_{CC}=2.0V\sim 10V$	
Frequency variation with temperature	$f_{\Delta T}$	-	5	-	%	$T_a=-20^{\circ}C\sim 85^{\circ}C$	
Error Amplifier							
Threshold voltage	V_{Ea}	480	500	520	mV	$V_{FB}=0.45V$	
Line regulation	$V_{Ea\Delta V}$	-	1	4	%	$V_{CC}=2.0V\sim 10V$	
Variation with temperature	$V_{Ea\Delta T}$	-	1	-	%	$T_a=-20^{\circ}C\sim 85^{\circ}C$	
Input bias current	I_{EaIn}	-1.0	-0.2	1.0	μA	$V_{EaIn}=0V$	
Voltage gain	A_V	35.5	38.5	41.5	dB		
Gain Band Width	GBW	-	6	-	MHz	$A_V=0dB$	
Output high voltage	$V_{EaOut, High}$	0.78	0.87	-	V	$V_{EaIn}=0V$	
Output low voltage	$V_{EaOut, Low}$	-	0.05	0.2	V	$V_{EaIn}=1.0V$	
Output source current	$I_{EaOut, Source}$	-	-40	-24	μA	$V_{FB}=0.45V$	
Output sink current	$I_{EaOut, Sink}$	24	40	-	μA	$V_{FB}=0.45V$	
Dead time control							
Maximum duty cycle	D_{MAX}	65	75	85	%		
Output driver							
Output high voltage	$V_{Out, High}$	1.0	1.2	-	V	$I_{Out}=-15mA$	
Output low voltage	$V_{Out, Low}$	-	0.1	0.2	V	$I_{Out}=15mA$	
Output source current	$I_{Out, Source}$	-	-30	-20	mA	$V_{Out}=0.9V$	
Output sink current	$I_{Out, Sink}$	30	60	-	mA	$V_{Out}=0.3V$	
Pull-down resistor	R_{Out}	20	30	40	k Ω		
Output drive control							
Pin voltage	V_{BR}	0.25	0.35	0.45	V	$R_{BR}=620\Omega$	
Input off condition	$I_{BR, Off}$	-15	-	0	μA		
Input on condition	$I_{BR, On}$	-	-	-45	μA		
Pin current range	I_{BR}	-0.9	-	-0.1	mA		
Entire device							
Supply Current	On mode	$I_{CC, On}$	-	5.0	9.0	mA	$R_{BR}=620\Omega$
	Off mode	$I_{CC, Off}$	-	0.1	1.0	μA	$BR/CTL Pin=V_{CC}$
	Latch mode	$I_{CC, LT}$	-	5.3	9.5	mA	S.C.P. is operating

9. TEST CIRCUIT

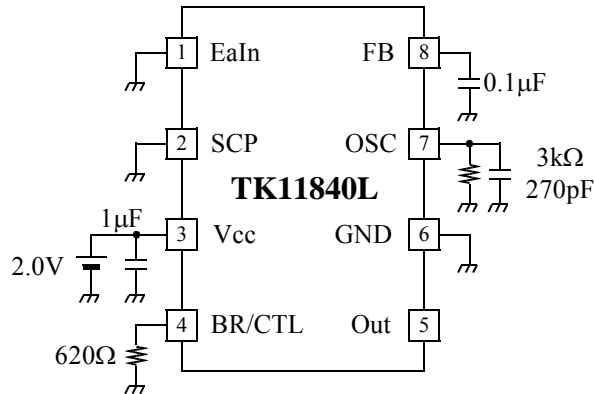

10. TYPICAL CHARACTERISTICS

■ Supply current vs. Supply voltage (On mode)

$T_a=25^\circ\text{C}$, $R_{BR}=620\Omega$

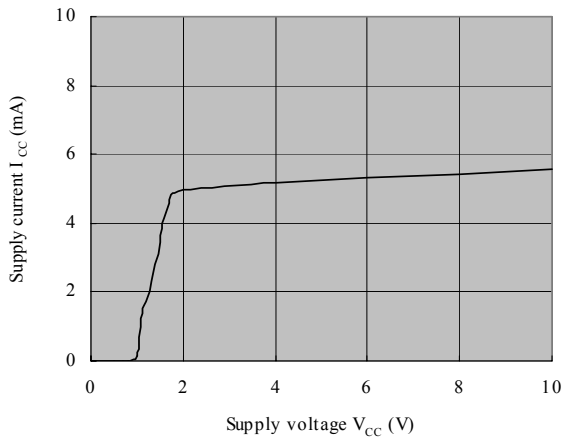

■ EaIn threshold voltage vs. Supply voltage

$T_a=25^\circ\text{C}$

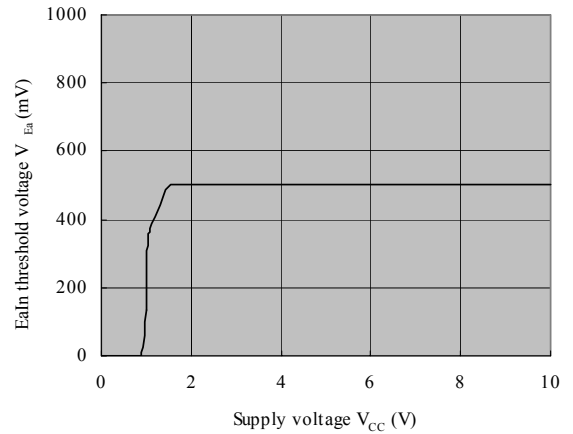

■ EaIn threshold voltage variation ratio vs. Supply voltage

$T_a=25^\circ\text{C}$

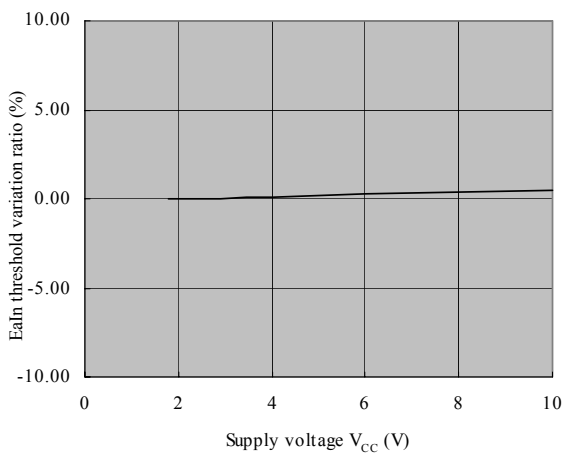

■ EaIn threshold voltage variation ratio vs. Ambient temperature

$V_{CC}=2.0\text{V}$

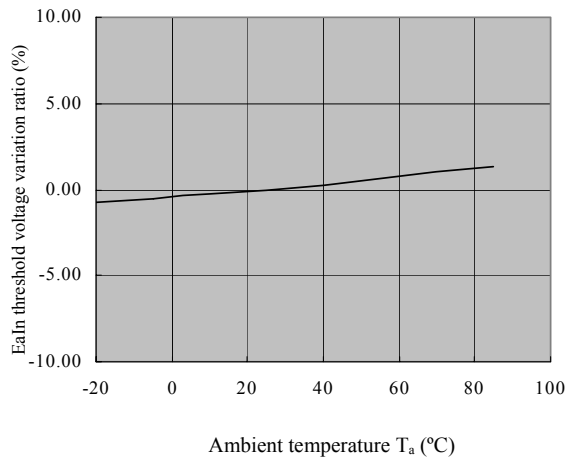

■ Output source current vs. BR/CTL pin current
 $V_{CC}=2.0V, T_a=25^\circ C$

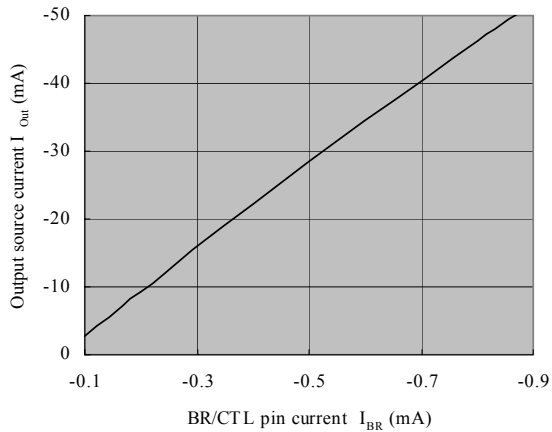

■ BR/CTL pin voltage vs. BR/CTL pin current
 $V_{CC}=2.0V, T_a=25^\circ C$

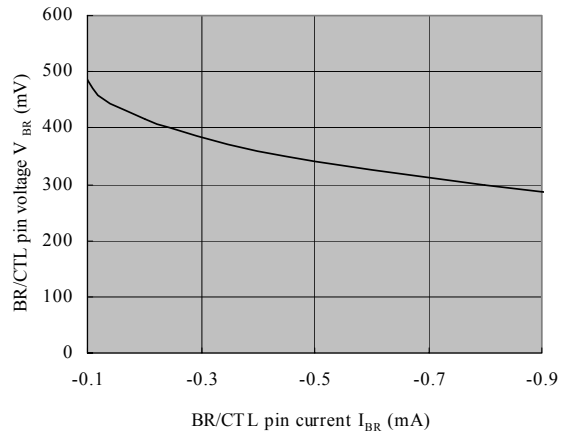

■ Oscillation frequency vs. Timing resistor
 $V_{CC}=2.0V, T_a=25^\circ C$

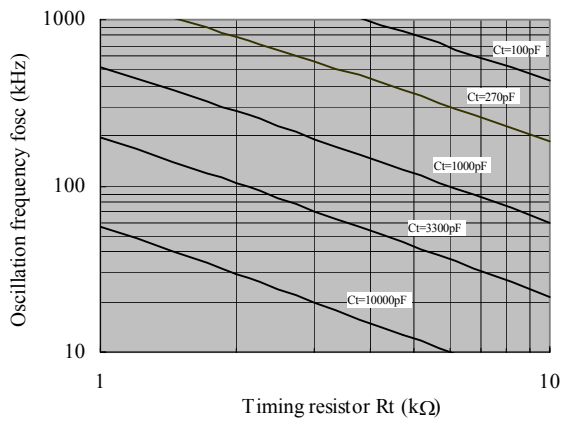

■ Frequency variation ratio vs. Supply voltage
 $C_t=270pF, R_t=3k\Omega, T_a=25^\circ C$

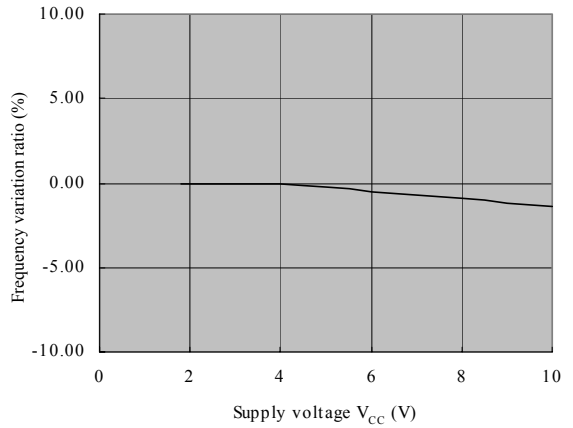

■ Frequency variation ratio vs. Ambient temperature
 $V_{CC}=2.0V, C_t=270pF, R_t=3k\Omega$

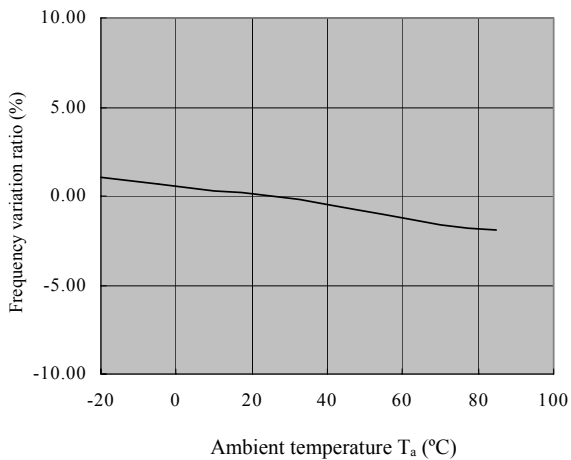

11. CIRCUIT DESCRIPTION

12-1. Setting the output voltage

To obtain a regulated output voltage for most common step-up regulator applications, connect a voltage-divider from the output (Vout) to EaIn. (See Fig1)

The output voltage is determined by the 0.5V reference level and by the selection of two external resistors according to the equation.

$$V_{out} = V_{Ref} \times \left(1 + \frac{R2}{R1}\right)$$

where $V_{Ref}=0.5V$

The input bias current of EaIn has $-0.2\mu A$. typical .

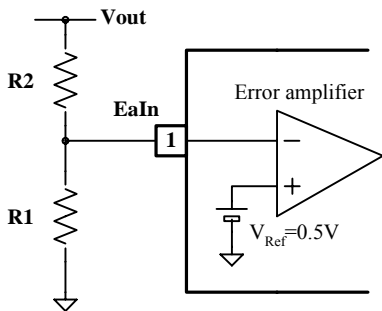

Fig1: Setting the output voltage

12-2. Shutdown

To disable the device (shutdown mode), set BR/CTL Pin (Pin 4) open or connect to V_{CC} as shown in Fig 2. During shutdown, the supply current of the IC drops to $1\mu A$ or less.

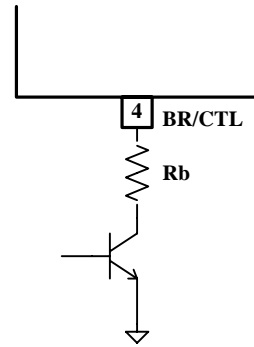

Fig2: Shutdown

12-3. Sawtooth wave Oscillator

The oscillator operates by rapidly charging an external capacitor C_t and resistor R_t with a current from a lower threshold voltage $V_{OSC,L}$ to an upper threshold voltage $V_{OSC,H}$.

Once the C_t voltage reaches the upper threshold voltage, the capacitor is slowly discharged back through resistor R_t to the lower threshold voltage.

The oscillator frequency can be expressed as

$$f_{OSC} \approx \frac{1}{C_t \cdot R_t \cdot \ln \frac{V_{OSC,H}}{V_{OSC,L}} + t_{Rise}}$$

where $V_{OSC,H}=800mV$
 $V_{OSC,L}=100mV$
 $t_{Rise}=0.1\mu Sec$

This equation is rough estimate, because it takes no account of overshoot around the upper threshold level when C_t is charged rapidly.

A plot of OSC frequency vs. R_t and C_t is shown in Fig 3.

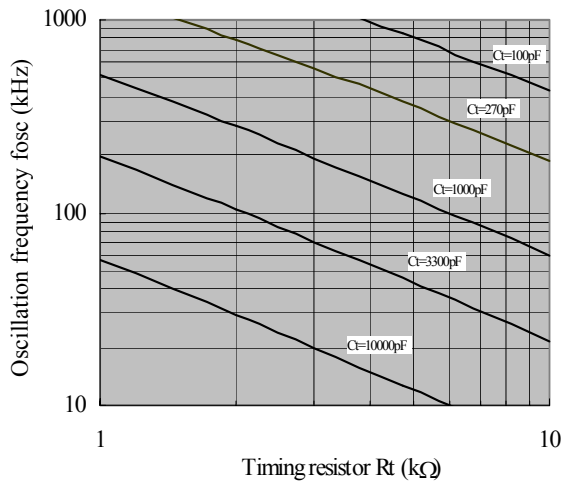

Fig.3: Oscillator frequency vs. Timing resistor

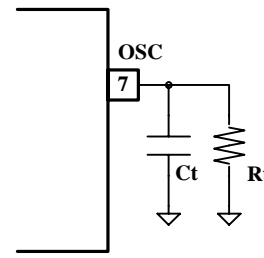
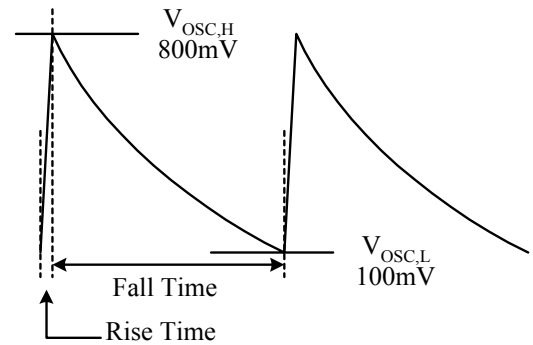

Fig 4. Oscillator pin connection



* $t_{Rise}=0.1\mu Sec$

Fig 5. Oscillator waveform

12-4. Setting the output source current

The TK11840L is designed to drive an external bipolar NPN switching transistor, enabling high efficiency conversion with low input voltages. The output current which is a base current of the NPN switching transistor is set by a resistor Rb at pin4. This function ensures optimum efficiency over a wider range of load currents. The optimum Rb value should be determined by experiment in an actual circuit.

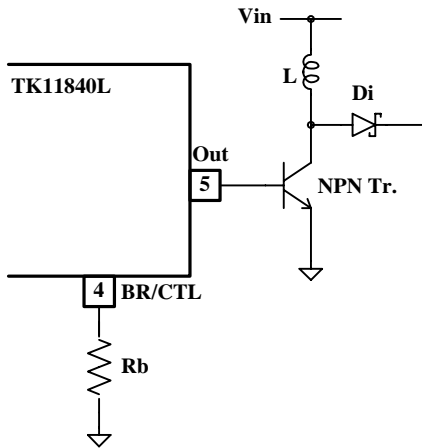

Fig6: Programming output current

The output current can be expressed as

$$I_{Out,source} = \alpha \cdot I_{BR}$$

$$I_{BR} = \frac{V_{BR}}{R_b}$$

where, V_{BR} is a voltage across the resistor Rb at pin4. I_{BR} is the current through Rb to GND.

α : A proportional coefficient which is approximately 50.

Fig.7 shows BR/CTL pin voltage (V_{BR}) vs. BR/CTL pin current (I_{BR}).

Fig.8 show output source current ($I_{Out, Source}$) vs. BR/CTL pin current (I_{BR}).

For example follows

$$\begin{aligned} I_{Out,source} &= -10\text{mA} \\ I_{BR} &= -0.2\text{mA} \text{ (from Fig.8)} \\ V_{BR} &= 0.4\text{V} \text{ (from Fig.7)} \\ \therefore R_b &= \frac{V_{BR}}{I_{BR}} = 2\text{k}\Omega \end{aligned}$$

The value of output source current ($I_{Out,Source}$) is 50mA maximum.

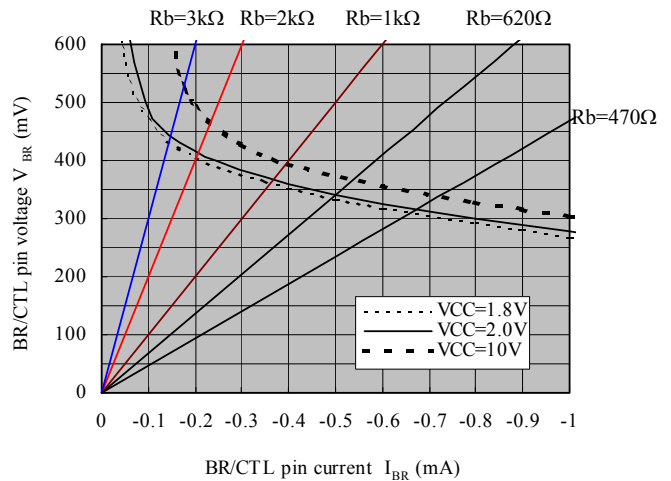

Fig 7. BR/CTL pin voltage vs. BR/CTL pin current

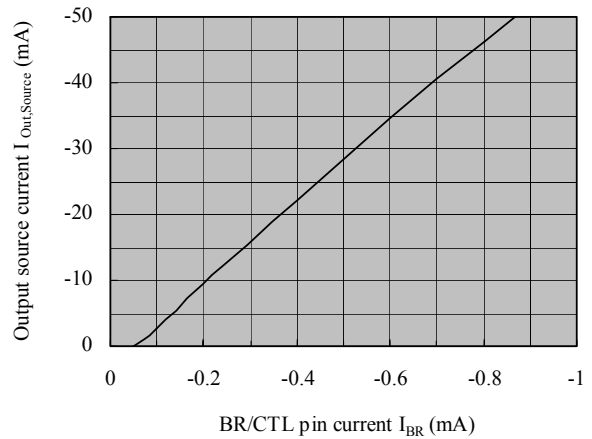

Fig 8. Output source current vs. BR/CTL pin current

12-5. Maximum output source current

Power dissipation within the IC package is a maximum 150mW at $T_a = 85^\circ\text{C}$ (ambient temperature)

The power dissipation of IC increases directly with input voltage and output current, which can be expressed as the following relation.

$$P_D \approx V_{CC} \cdot I_{Out,Source} \cdot \text{Duty}$$

Fig.9 shows an allowable output current setting area (safety area) under this condition. (150mW at $T_a = 85^\circ\text{C}$) Output current must be set within the safe area. (which is lower than 50mA and "Duty line" in application circuit.)

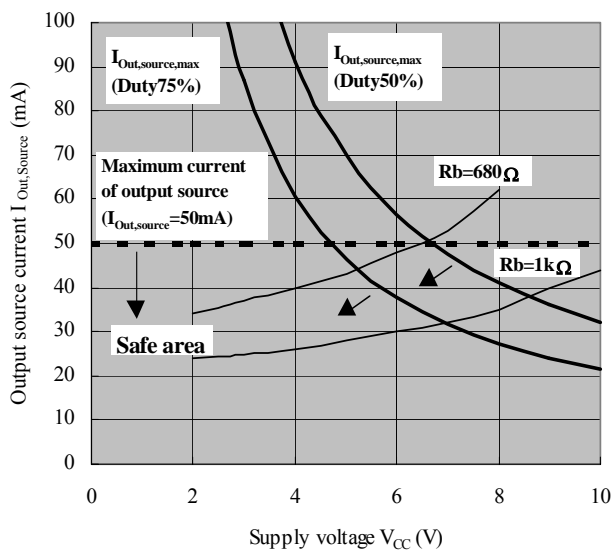

Fig 9. Output source current vs. supply voltage

12-6. Soft start and Short circuit detection

The TK11840L incorporates a soft start function and short circuit detection.

A capacitor C_{scp} connected to the SCP pin (pin2) is a dual purpose capacitor, one is for soft start function and the other is for short circuit detection. When the IC is first activated, the capacitor C_{scp} on the SCP pin is charged with about $1.2\mu\text{A}$ by internal current source.

The PWM comparator compares the soft start setting voltage as a proportion of the voltage at the SCP pin with the sawtooth waveform. The ON duty of the output pin is gradually increased by the PWM comparator output signal.

Soft start time (the time until the output ON duty reaches approximately 50%) is determined by

$$t_{SS} [S] \approx \frac{C_{scp} [\mu F]}{I_{SS} [\mu A]} \cdot 0.4 [V] \approx 0.33 \cdot C_{scp} [\mu F]$$

where I_{SS} is internal current source of $1.2\mu\text{A}$ (Typ.).

After soft start operation is over, the voltage of SCP pin returns low and enters the short circuit detection wait state. When an output short circuit occurs as output suddenly drops due to load effect, the error amplifier output is fixed at $V_{EaOut,High}$ and capacitor C_{scp} starts charging with about $1.2\mu\text{A}$. When the voltage of C_{scp} reaches about 0.75V, the output pin (pin5) is set low and the SCP pin (pin2) stays low.

Short circuit detection time is

$$t_{SCP} [S] \approx \frac{C_{scp} [\mu F]}{I_{SCP} [\mu A]} \cdot 0.75 [V] = 0.625 \cdot C_{scp} [\mu F]$$

where I_{SCP} is internal current source of $1.2\mu\text{A}$ (Typ.).

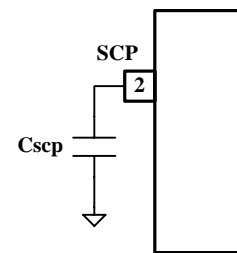

Fig 10. SCP pin connection

Once the protection circuit operates, the timer latch circuit can be restored by resetting the power supply.

Fig.11 shows the timing Diagram of soft start and short circuit detection.

Note :

In application of the simple step-up circuit, the short circuit detection circuitry is not in series with the power path from input to load.

This short circuit detection makes the external switch transistor turn off only.

■ Timing Diagram of soft start and short circuit detection.

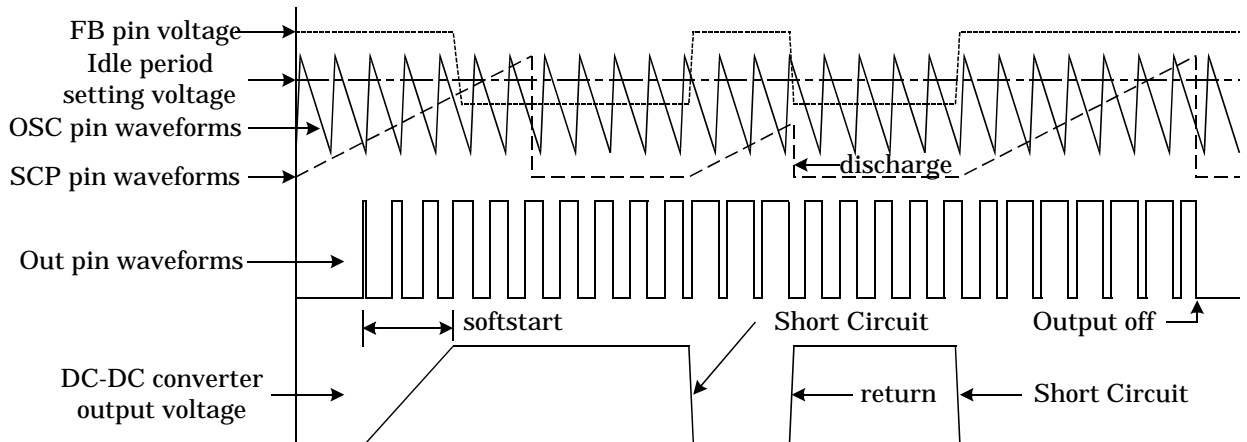

Fig.11: Timing Diagram of soft start and short circuit detection.

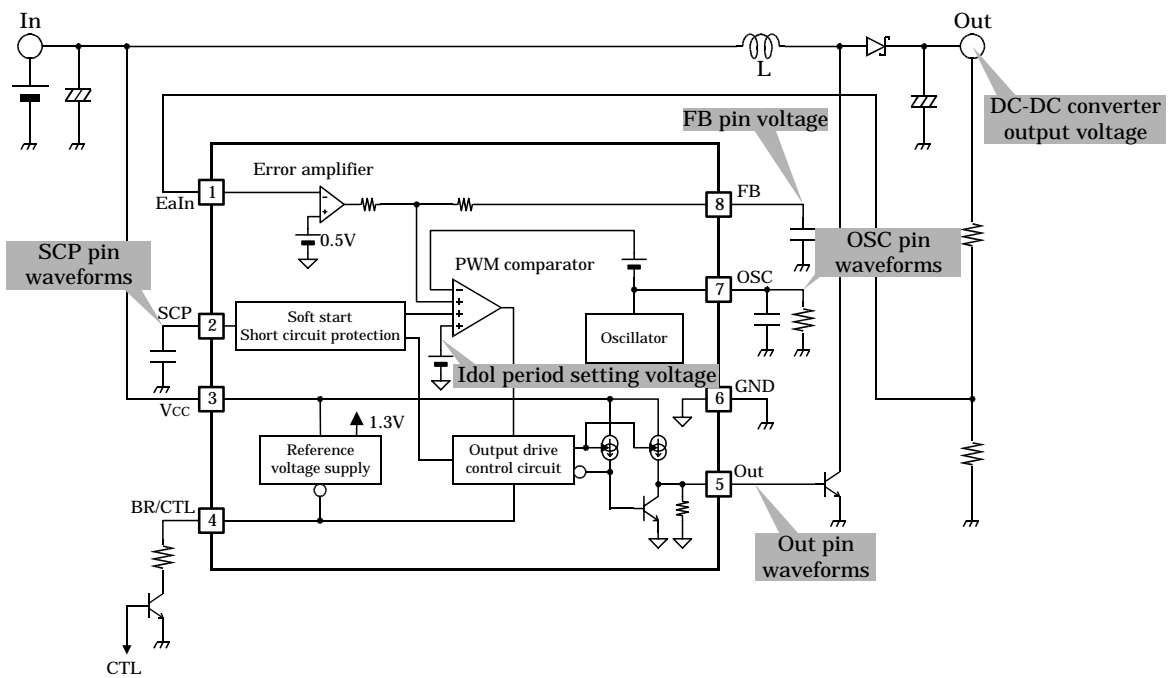

Fig.12: Minimum step-up application

12. APPLICATIONS INFORMATION

■ Step-up DC-DC converter application

Typical application for 2.7V to 5V 100mA DC-DC Converter.

- Vin=2.7V
- Vout=5.0V
- Iout=100mA

Figure13: 2.7V to 5V 100mA DC-DC Converter

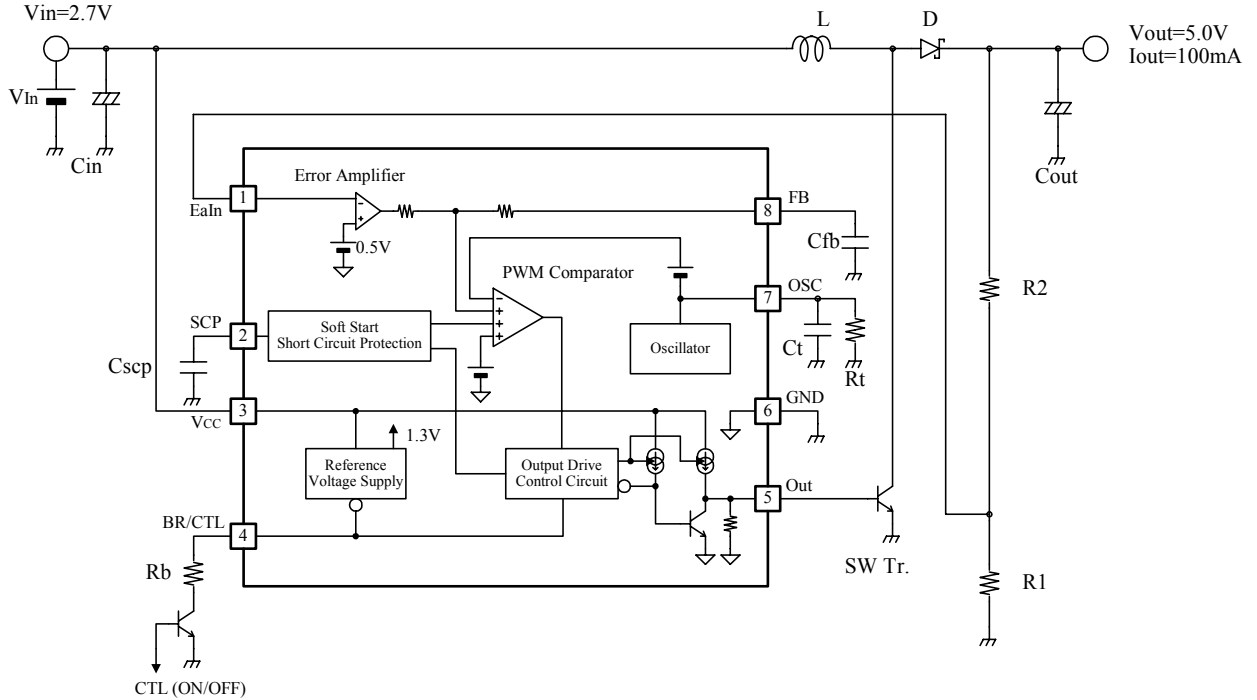

• **Value of component**

- L= 15μH (TOKO D52LC TYPE *Parts No.A914BYW-150M)
- Cin=10μF/6.3V, Cout=10μF/6.3V
- Cfb=0.1μF, Cscp=0.1μF
- Ct= 270pF , Rt= 2.2kΩ (Oscillator Frequency 730kHz)
- Rb=2.0kΩ
- R1=10kΩ, R2=91kΩ (Vout=5.0V)

• **Output voltage setting**

Set the output voltage by selecting values for R1 and R2.
The regulated output voltage is determined by

$$V_{Out} = V_{Ref} \left(1 + \frac{R2}{R1} \right)$$

$$V_{Ref} = 0.5V$$

■ White-LED Drive application

Typical application for 6LEDs/20mA in series.

- $V_{in}=2.5V$
- $I_{LED}=20mA$

Figure14: White-LED Driver (6LEDs in series)

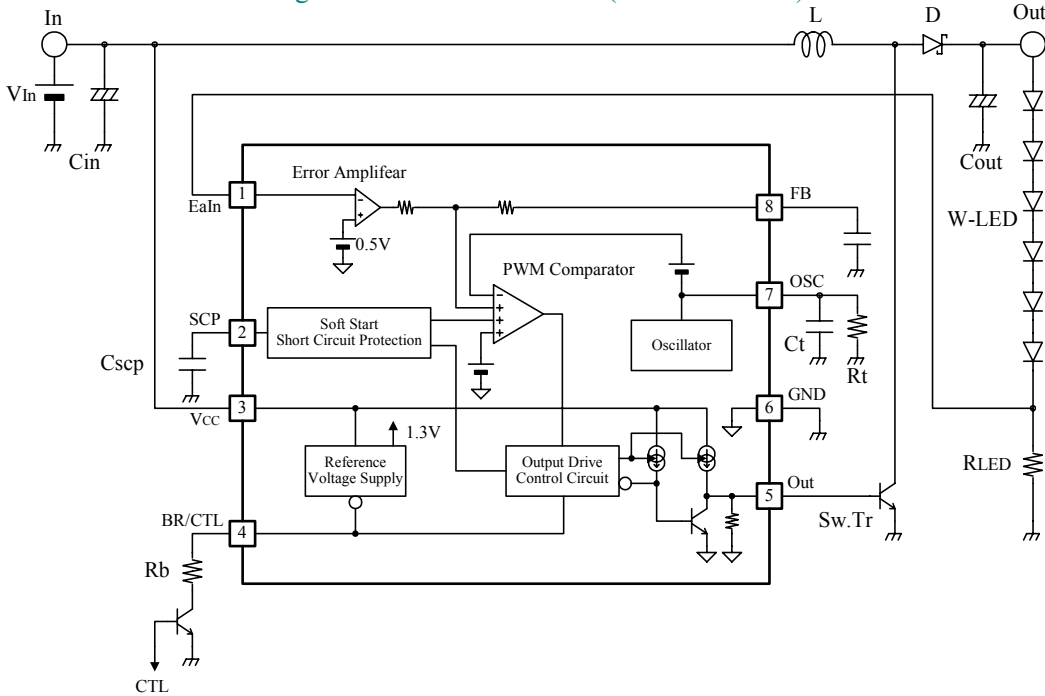

• Value of component

- $L=10\mu H$ (TOKO D52LC TYPE *Parts No.A914BYW-100M)
- $C_{in}=4.7\mu F$, $C_{out}=2.2\mu F$
- $C_t=270pF$, $R_t=6.8k\Omega$ (Oscillator Frequency:260kHz)
- $C_{fb}=0.1\mu F$, $C_{scp}=0.1\mu F$
- $R_b=2.0k\Omega$

$$R_{LED}=24\Omega \left(I_{LED} = \frac{V_{Ref}}{R_{LED}} = \frac{0.5}{24} = 20.8mA \right)$$

• LED current setting

The LEDs current (I_{LED}) is set by an external resistor (R_{LED}) connected between the EaIn pin and GND. The current of each LED is same as

$$I_{LED} = \frac{V_{Ref}}{R_{LED}}$$

where V_{Ref} : the feedback reference voltage 0.5V

Output voltage V_{out} is given by

$$V_{out} = n \cdot V_f + V_{Ref}$$

where V_f : LED forward voltage drop

n : Number of LEDs in series connection

13. NOTES

■ Please be sure that you carefully discuss your planned purchase with our office if you intend to use the products in this application manual under conditions where particularly extreme standards of reliability are required, or if you intend to use products for applications other than those listed in this application manual.

- Power drive products for automobile, ship or aircraft transport systems; steering and navigation systems, emergency signal communications systems, and any system other than those mentioned above which include electronic sensors, measuring, or display devices, and which could cause major damage to life, limb or property if misused or failure to function.

- Medical devices for measuring blood pressure, pulse, etc., treatment units such as coronary pacemakers and heat treatment units, and devices such as artificial organs and artificial limb systems which augment physiological functions.

- Electrical instruments, equipment or systems used in disaster or crime prevention.

■ Semiconductors, by nature, may fail or malfunction in spite of our devotion to improve product quality and reliability. We urge you to take every possible precaution against physical injuries, fire or other damages which may cause failure of our semiconductor products by taking appropriate measures, including a reasonable safety margin, malfunction preventive practices and fire-proofing when designing your products.

■ This application manual is effective from Dec. 2006. Note that the contents are subject to change or discontinuation without notice. When placing orders, please confirm specifications and delivery condition in writing.

■ TOKO is not responsible for any problems nor for any infringement of third party patents or any other intellectual property rights that may arise from the use or method of use of the products listed in this application manual. Moreover, this application manual does not signify that TOKO agrees implicitly or explicitly to license any patent rights or other intellectual property rights which it holds.

■ None of the ozone depleting substances(ODS) under the Montreal Protocol are used in our manufacturing process.

14. OFFICES

If you need more information on this product and other TOKO products, please contact us.

■ TOKO Inc. Headquarters
 1-17, Higashi-yukigaya 2-chome, Ohta-ku, Tokyo,
 145-8585, Japan
 TEL: +81.3.3727.1161
 FAX: +81.3.3727.1176 or +81.3.3727.1169
 Web site: <http://www.toko.co.jp/>

■ TOKO America
 Web site: <http://www.toko.com/>

■ TOKO Europe
 Web site: <http://www.tokoeurope.com/>

■ TOKO Hong Kong
 Web site: <http://www.toko.com.hk/>

■ TOKO Taiwan
 Web site: <http://www.tokohc.com.tw/>

■ TOKO Singapore
 Web site: <http://www.toko.com.sg/>

■ TOKO Seoul
 Web site: <http://www.toko.co.kr/>

■ TOKO Manila
 Web site: <http://www.toko.com.ph/>

■ TOKO Brazil
 Web site: <http://www.toko.com.br/>



Semiconductor Division

YOUR DISTRIBUTOR